

SUBSTRUCTURE REPAIRS AT PIERS 16 AND 17 HONOLULU HARBOR, OAHU, HAWAII

FOR THE
STATE OF HAWAII
DEPARTMENT OF TRANSPORTATION
HARBORS DIVISION
S10852

CONSULTANT:

MKE ASSOCIATES LLC
STRUCTURAL ENGINEER

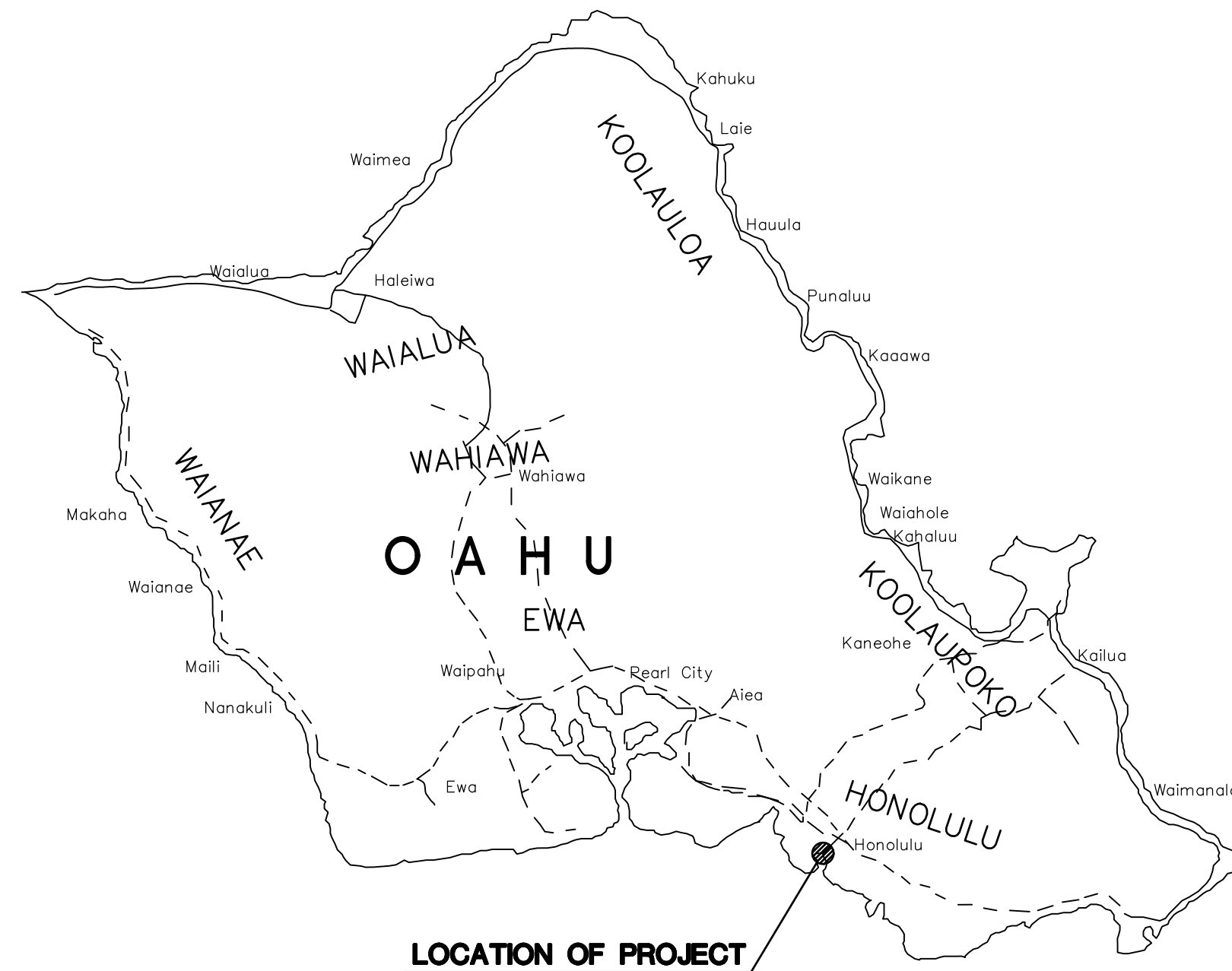

ISLAND OF OAHU

LOCATION MAP

NOT TO SCALE

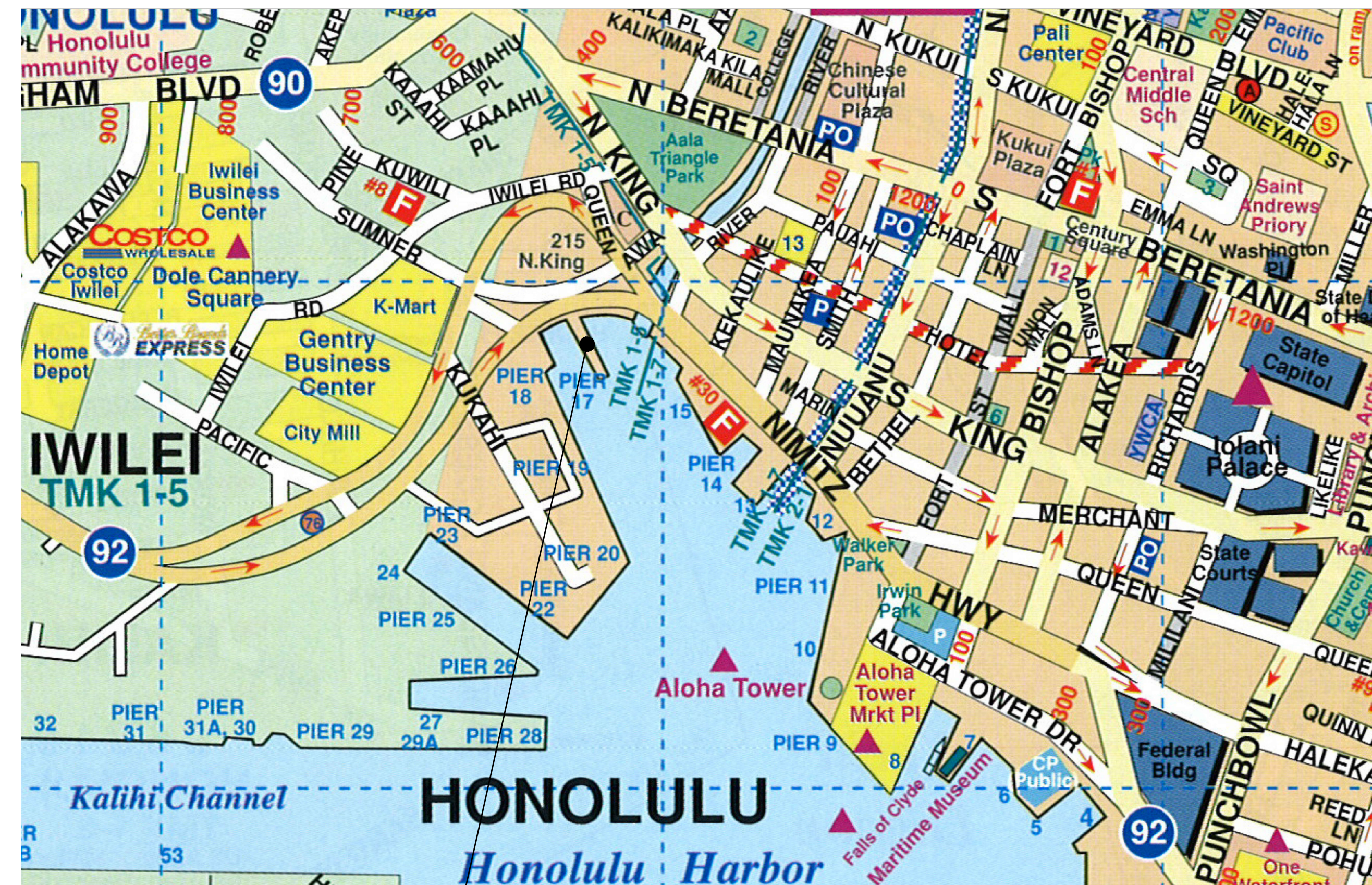
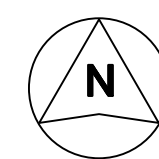

PROJECT SITE

VICINITY MAP

NOT TO SCALE

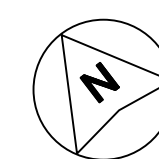

DEPARTMENT OF TRANSPORTATION STATE OF HAWAII		SHEET T-1
APPROVED BY: <i>[Signature]</i>	DATE: Apr 28, 2023	
FOR DIRECTOR OF TRANSPORTATION	DATE	1 of 14 SHEETS

INDEX TO DRAWINGS

SHEET NO.	TITLE
T-1	TITLE SHEET, LOCATION AND VICINITY MAPS
T-2	INDEX TO DRAWINGS AND GENERAL PLAN
S-1	STRUCTURAL NOTES
S-2	PARTIAL PIER 16 PLAN
S-3	PARTIAL PIER 16 PLAN
S-4	PARTIAL PIER 17 PLAN
S-5	CONNECTOR ROAD PIER PLAN
S-6	TYPICAL PIER SECTIONS
S-7	TYPICAL PIER SECTIONS
S-8	SLAB SOFFIT AND VERTICAL SPALL REPAIR DETAILS
S-9	BEAM SPALL REPAIR DETAILS
S-10	PRESTRESS DOUBLE TEE REPAIR DETAILS
S-11	PRECAST PLANK SOFFIT SPALL REPAIR DETAILS
S-12	TYPICAL REPAIR DETAILS

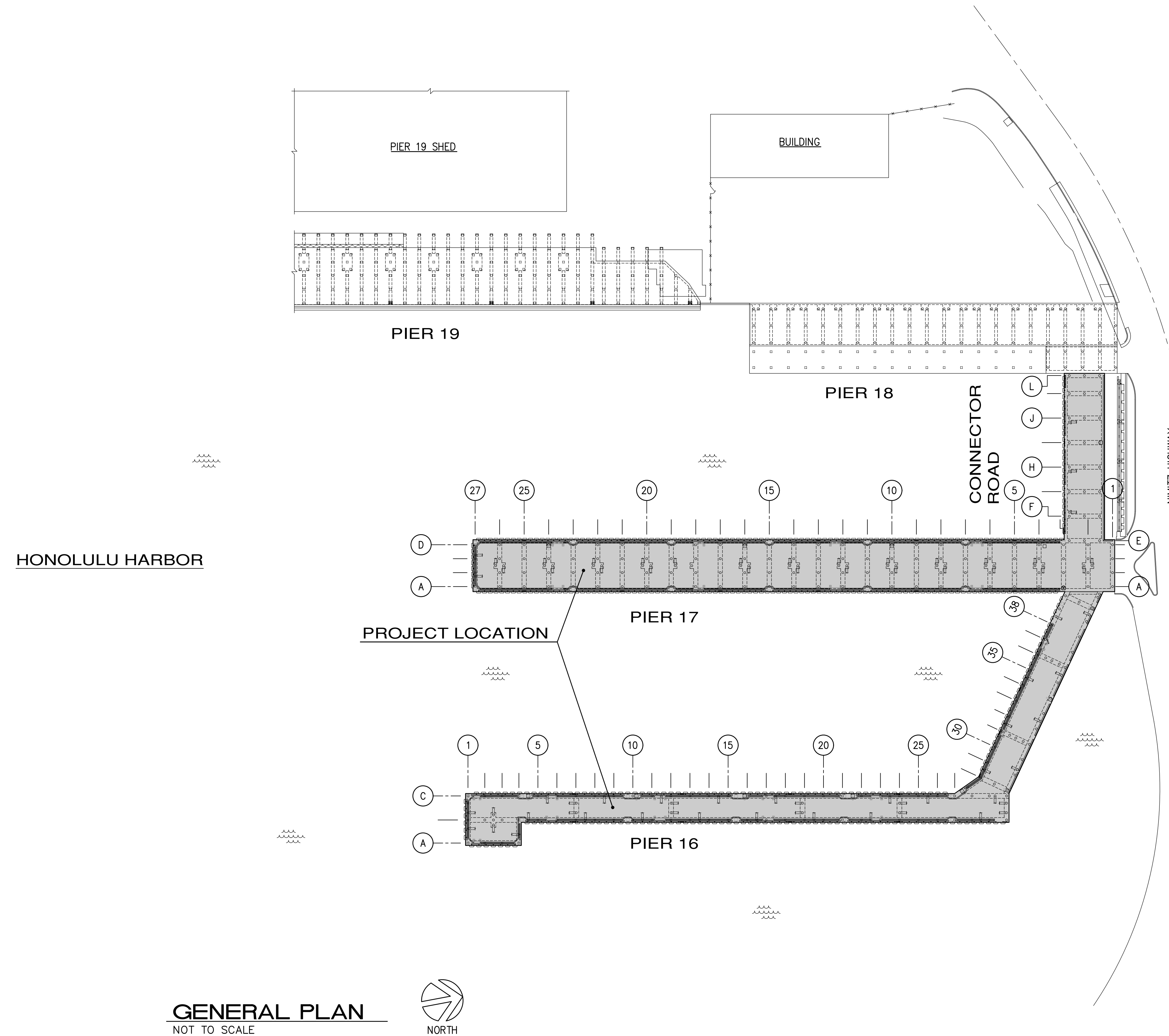

GENERAL PLAN
NOT TO SCALE

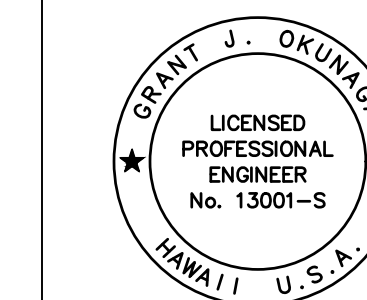

THIS WORK WAS PREPARED BY ME
OR UNDER MY SUPERVISION
EXP. 4-30-24
Grant J. Okunaka
MKE ASSOCIATES LLC

REVISION	DATE	DESCRIPTION	BY	APPROVED
STATE OF HAWAII DEPARTMENT OF TRANSPORTATION HARBORS DIVISION				
JOB TITLE SUBSTRUCTURE REPAIRS AT PIERS 16 AND 17 HONOLULU HARBOR, OAHU, HAWAII				
SHEET TITLE INDEX TO DRAWINGS AND GENERAL PLAN				
DESIGNED BY: GO				SHEET T-2
DRAWN BY: DL				JOB NUMBER S10852
CHECKED BY: GM				
DATE: 04/2023				
SCALE: AS SHOWN				2 of 14 SHTS.

STRUCTURAL NOTES:

GENERAL:

- WORKMANSHIP AND MATERIALS SHALL CONFORM TO THE HAWAII STANDARD SPECIFICATION FOR ROAD AND BRIDGE CONSTRUCTION, 2005, FOR THE STATE OF HAWAII, UNLESS OTHERWISE INDICATED. HOWEVER, WHERE REFERENCE IS MADE TO PERFORMANCE CONFORMING TO OTHER STANDARDS THE MORE STRINGENT SHALL APPLY.
- THE CONTRACTOR SHALL COMPARE PLANS, SPECIFICATIONS AND ALL OTHER CONTRACT DOCUMENTS WITH EACH OTHER AND REPORT IN WRITING TO THE HARBORS DIVISION CONSTRUCTION ENGINEER ALL INCONSISTENCIES AND OMISSIONS.
- THE CONTRACTOR SHALL TAKE FIELD MEASUREMENTS AND VERIFY FIELD CONDITIONS AND SHALL COMPARE SUCH FIELD MEASUREMENTS AND CONDITIONS WITH THE DRAWINGS BEFORE COMMENCING WORK. REPORT IN WRITING TO THE HARBORS DIVISION CONSTRUCTION ENGINEER ALL INCONSISTENCIES AND OMISSIONS.
- CONTRACTOR SHALL RESOLVE ANY DISCREPANCIES AND QUESTIONS PRIOR TO THE START OF WORK. NO EXTRA PAYMENT SHALL BE ALLOWED ON ACCOUNT OF WORK MADE NECESSARY BY CONTRACTORS FAILURE TO VISIT THE SITE AND/OR FAILURE TO RESOLVE DISCREPANCIES AND QUESTIONS.
- THE CONTRACTOR SHALL PROTECT ALL UTILITIES AND STRUCTURES IN AND ADJACENT TO THE PROJECT SITE. ANY DAMAGE SHALL BE REPAIRED TO THE SATISFACTION OF THE HARBORS DIVISION CONSTRUCTION ENGINEER AND PAID FOR BY THE CONTRACTOR.
- THE CONTRACTOR SHALL BE RESPONSIBLE FOR COORDINATING THE WORK OF ALL TRADES.
- THE CONTRACTOR SHALL COORDINATE HIS/HER WORK WITH OTHER CONTRACTORS WITHIN THE PROJECT AREA. THE CONTRACTOR SHALL ALSO COORDINATE WITH THE HARBORS DIVISION OAHU DISTRICT MANAGER AND CONSTRUCTION ENGINEER FOR AN APPROVED STAGING AND STORAGE AREA AND FOR RESTRICTIONS OF HARBORS OPERATIONS OVER REPAIR AREAS.
- THE CONTRACTOR SHALL REMOVE ALL DEBRIS RESULTING FROM HIS/HER WORK AS REQUIRED FOR PUBLIC HEALTH AND SAFETY AND TO THE SATISFACTION OF THE HARBORS DIVISION CONSTRUCTION ENGINEER. SHOULD THE STATE PERFORM ANY OF THE ABOVE WORK DUE TO NON-PERFORMANCE BY THE CONTRACTOR, THE CONTRACTOR AGREES TO REIMBURSE THE STATE FOR ALL COSTS INCURRED.
- HARBOR OPERATIONS TAKE PRECEDENCE OVER CONSTRUCTION ACTIVITY. THE CONTRACTOR MUST WORK AROUND HARBOR OPERATIONS SO THAT THE PIERS WILL REMAIN OPERATIONAL. WEEKEND WORK MAY BE REQUIRED AND SHALL BE COORDINATED WITH THE HARBORS DIVISION CONSTRUCTION ENGINEER AND TENANTS IN ADVANCE.
- THE CONTRACTOR SHALL BE RESPONSIBLE FOR METHODS OF CONSTRUCTION, WORKMANSHIP AND JOB SAFETY. THE CONTRACTOR SHALL PROVIDE TEMPORARY SHORING AND BRACING AS REQUIRED FOR STABILITY OF STRUCTURAL MEMBERS AND SYSTEMS.
- ALL WORK SPECIFIED IN THE CONTRACT BUT NOT LISTED SEPARATELY SHALL BE CONSIDERED INCIDENTAL AND WILL NOT BE PAID FOR SEPARATELY.
- NOTES AND DETAILS ON THE PLANS SHALL TAKE PRECEDENCE OVER GENERAL NOTES AND TYPICAL DETAILS. SHOULD THERE BE CONFLICTS BETWEEN THE REQUIREMENTS OF THE PLANS OR SPECIFICATIONS, THE MORE STRINGENT SHALL APPLY.
- THE CONTRACTOR SHALL COMPLY WITH THE CLEAN WATER ACT AND THE STATE HARBORS DIVISION STORMWATER MANAGEMENT PROGRAM. NO POLLUTANTS ARE ALLOWED TO BE DISCHARGED DIRECTLY OR INDIRECTLY THROUGH THE HARBORS SMALL MS4 OR OTHER POTENTIAL PATHWAY INTO HARBOR WATERS.
- THE CONTRACTOR WILL BE RESPONSIBLE FOR REGULATORY FINES OR PENALTIES THAT MAY BE IMPOSED BY ENVIRONMENTAL REGULATORY AGENCIES (EPA AND/OR STATE DOH) IN THE EVENT OF VIOLATIONS.
- THE CONTRACTOR SHALL SUBMIT A SITE-SPECIFIC BEST MANAGEMENT PRACTICES (BMP) PLAN TO HARBORS DIVISION ENGINEER BRANCH PRIOR TO THE START OF ANY CONSTRUCTION WORK. THE SITE SPECIFIC BMP PLAN SHALL COMPLY WITH ENVIRONMENTAL PROTECTION AND TEMPORARY WATER POLLUTION, DUST, AND EROSION CONTROL ARTICLES IN THE SPECIFICATIONS AND PROPOSAL.
- IN CASE OF SPILL, LEAK, OR OTHER RELEASE CONTAINING A HAZARDOUS SUBSTANCE OR OIL, THE CONTRACTOR SHALL NOTIFY APPROPRIATE FACILITY PERSONNEL, EMERGENCY RESPONSE AGENCIES, AND REGULATORY AGENCIES FOLLOWING NOTIFICATION PROCEDURES, AND SHALL NOTIFY THE HARBORS DIVISION CONSTRUCTION ENGINEER IMMEDIATELY (I.E. WITHIN 24 HOURS). SUCH CONTACT INFORMATION MUST BE IN LOCATIONS THAT ARE READILY ACCESSIBLE AND AVAILABLE. CONTRACTOR SHALL NOTIFY THE HDOT HARBORS DIVISION ENGINEERING BRANCH ENVIRONMENTAL HOTLINE (808-587-1962) AND HDOT HARBORS DIVISION CONSTRUCTION ENGINEER OF ANY ILLICIT DISCHARGE AND/OR SPILL/RELEASE THAT OCCURS ONSITE.
- TIDAL DATA MAY NOT REPRESENT CONDITIONS THAT OCCUR DURING CONSTRUCTION AND ACTUAL WATER LEVELS WILL VARY FROM LEVELS INDICATED. THE CONTRACTOR IS RESPONSIBLE FOR MAKING THEIR OWN ESTIMATES OF WATER LEVELS WHICH MAY OCCUR DURING CONSTRUCTION. VARIATION FROM TIDAL LEVELS INDICATED OR CONTRACTOR'S ESTIMATION OF TIDAL LEVELS WILL NOT BE CONSIDERED AS A CLAIM FOR ADDITIONAL COMPENSATION OR DELAY OF WORK.

ORIGINAL PIER DESIGN LOADS:

- H20-16 WHEEL LOADS OR 500 PSF

PHASING NOTES:

- PHASING AND CAREFUL COORDINATION OF THE WORK WILL BE REQUIRED TO ALLOW CONTINUOUS USE OF THE PROJECT LOCATION AND ADJACENT AREAS.
- CONTRACTOR SHALL PERFORM THE WORK IN PHASES TO KEEP THE PIER AND CONNECTOR ROAD OPERATIONAL.
- SEE SPECIFICATIONS FOR ADDITIONAL PHASING INFORMATION.

CONCRETE:

- CONCRETE CONSTRUCTION SHALL CONFORM TO AMERICAN CONCRETE INSTITUTE ACI 318R-14 AND ACI 546R-14.
- FORMED CONCRETE SHALL HAVE A 28-DAY COMPRESSIVE STRENGTH OF $f'c=5,000$ PSI WITH SILICA FUME AND CORTEC MCI 2005 NS MIGRATING CORROSION INHIBITING ADMIXTURE, OR APPROVED EQUAL.
- MAXIMUM AGGREGATE SIZE SHALL BE $\frac{3}{8}$ INCHES AND SHALL BE COORDINATED WITH CONCRETE PREPARATION PROCEDURES FOR SPALL REPAIRS.
- CONCRETE DELIVERY TICKETS SHALL RECORD ALL FREE WATER IN THE MIX: AT BATCHING BY PLANT, FOR CONSISTENCY BY DRIVER, AND ANY ADDITIONAL REQUEST BY CONTRACTOR IF PERMITTED BY THE MIX DESIGN.
- MAXIMUM WATER TO CEMENTITIOUS MATERIALS RATIO SHALL BE 0.40.
- PATCHING COMPOUND FOR FORM AND POUR SPALL REPAIRS SHALL BE SIKACRETE 211 SCC PLUS BY SIKA, OR APPROVED EQUAL.
- PATCHING COMPOUND FOR REPAIRING VERTICAL AND SOFFIT SPALLS IN LIFTS SHALL BE SIKAQUICK VOH WITH LATEX R BY SIKA, OR APPROVED EQUAL.
- REINFORCING BARS, ANCHOR BOLTS, INSERTS, AND OTHER ITEMS TO BE CAST IN THE CONCRETE SHALL BE SECURED IN POSITION PRIOR TO PLACEMENT OF CONCRETE.

REINFORCING STEEL:

- REINFORCING STEEL FOR WELD SPLICING SHALL BE ASTM A706 GRADE 60. WELDING ELECTRODES SHALL BE LOW HYDROGEN E70.
- REINFORCING STEEL NOT TO BE WELD SPLICED SHALL BE ASTM A615, GRADE 60 OR ASTM A706 GRADE 60.
- CLEAR CONCRETE COVER FOR REINFORCING BARS SHALL BE 3 INCHES MINIMUM, UNLESS OTHERWISE NOTED.
- BAR BENDS AND HOOKS SHALL BE STANDARD HOOKS IN ACCORDANCE WITH ACI 318.
- REINFORCING STEEL SHALL BE SPLICED AS INDICATED ON PLANS. PROVIDE WELD SPLICE PER TYPICAL DETAILS, UNLESS OTHERWISE NOTED.
- ANTI-CORROSION COATING WITH A MINIMUM 7 DAY OPEN TIME FOR REINFORCING STEEL SHALL BE ARIMATEC 110 EPOCEM BY SIKA OR APPROVED EQUAL.
- EPOXY FOR GROUTING OF DOWELS SHALL BE SET-3G BY SIMPSON STRONG-TIE, OR APPROVED EQUAL.
- TIE WIRE SHALL BE PLASTIC-COATED, STAINLESS STEEL, OR MADE OF DIELECTRIC OR OTHER ACCEPTABLE MATERIAL. ALL LOOSE REINFORCING STEEL SHALL BE SECURED WITH TIES AT ALL INTERSECTIONS WITH ADJACENT REINFORCING STEEL.

MIGRATING CORROSION INHIBITOR:

- MIGRATING CORROSION INHIBITOR SHALL BE MCI-2020 V/O BY CORTEC, OR APPROVED EQUAL.
- APPLY MIGRATING CORROSION INHIBITOR TO ALL EXISTING PREPARED CONCRETE REPAIR SURFACES PRIOR TO PLACING REPAIR CONCRETE.

EPOXY COATING SYSTEM:

- EPOXY COATING SYSTEM SHALL BE TWO COATS OF AMERLOCK 400 BY PPG PROTECTIVE AND MARINE COATINGS, OR APPROVED EQUAL.
- CONCRETE REPAIRS SHALL BE ALLOWED TO CURE A MINIMUM OF 14 DAYS OR PER MANUFACTURER'S RECOMMENDATIONS BEFORE APPLYING EPOXY COATING SYSTEM.
- CLEAN ALL CONCRETE SURFACES TO BE COATED PER MANUFACTURER'S RECOMMENDATIONS.
- APPLY EPOXY COATING SYSTEM TO ALL REPAIRED SURFACES OF PLANKS AND CONCRETE SURFACES OF BEAMS ON THE UNDERSIDE OF THE PIER IN THE PROJECT LOCATION AS SHOWN.

GALVANIC ANODES:

- GALVANIC ANODES SHALL BE GALVASHIELD XP4 ANODES BY VECTOR CORROSION TECHNOLOGIES, OR APPROVED SUBSTITUTE.
- INSTALL ANODES PER MANUFACTURER'S RECOMMENDATIONS.

PREPARATION OF SUBSTRATE AND REINFORCING STEEL FOR SPALL REPAIRS:

- SURFACE PREPARATION FOR SPALL REPAIRS SHALL FOLLOW THE INTERNATIONAL CONCRETE REPAIR INSTITUTE (ICRI) GUIDELINE NO. 310.1R-2008.
- BOTH SPALLS AND DELAMINATIONS ARE REFERRED TO ON THE DRAWINGS AS "SPALLS", AS THE REPAIR PROCEDURES ARE THE SAME FOR BOTH CONDITIONS.
- THE CONTRACTOR SHALL SOUND ALL CONCRETE SURFACES TO IDENTIFY SPALLS AND DELAMINATIONS.
- ANY ELEMENT BEING REPAIRED SHALL NOT BE SUBJECTED TO LIVE LOADS DURING THE PERIOD STARTING FROM THE REMOVAL OF EXISTING CONCRETE UNTIL THE REPAIR CONCRETE HAS OBTAINED A MINIMUM COMPRESSIVE STRENGTH OF 4,000 PSI.
- PREPARATION OF SUBSTRATE AND REINFORCING STEEL FOR SPALL REPAIRS SHALL BE PERFORMED IN THE ORDER LISTED BELOW.
- THE SPALLED AND DELAMINATED CONCRETE SHALL BE COMPLETELY REMOVED TO SOUND SUBSTRATE AND BEYOND THE EXTENT OF THE CORRODED REINFORCING. THE CONTRACTOR SHALL TAKE THE NECESSARY PRECAUTIONS TO AVOID DAMAGING THE UNDERLYING SOUND CONCRETE.
- THE SPALLED AND DELAMINATED EDGES SHALL BE SQUARED BY SAW-CUTTING AND CHIPPING THE CONCRETE AT THE PERIMETER BEYOND THE REMOVAL AREA AS NECESSARY TO ATTAIN A MINIMUM DEPTH OF $\frac{3}{4}$ INCH AND TO PREVENT FEATHER EDGE CONDITIONS. EXERCISE GREAT CARE TO AVOID CUTTING OR DAMAGING ANY EXISTING EMBEDDED STEEL REINFORCING. ANGLES BETWEEN ADJACENT SAW-CUTS AROUND THE PERIMETER SHALL NOT BE LESS THAN 90 DEGREES AND THE SHAPE OF EACH PATCH SHALL NOT BE IRREGULAR.
- FOR ANY EXPOSED REINFORCEMENT WITHIN THE REPAIR AREA, ADDITIONAL CONCRETE SHALL BE REMOVED FOR A MINIMUM $\frac{3}{4}$ INCH CLEAR SPACE MEASURED RADIALLY AROUND THE BARS.
- EXISTING CONCRETE SURFACES WITHIN THE REPAIR AREAS SHALL BE ROUGHENED TO ENSURE PROPER ADHESION WITH REPAIR CONCRETE.
- ALL EXPOSED CONCRETE SURFACES AND REINFORCING BARS IN THE REPAIR AREA SHALL BE NEEDLE GUNNED TO REMOVE ALL SCALE, LOOSE RUST, DEBRIS AND DETERIORATED CONCRETE.
- ANY REINFORCEMENT WHICH HAS LOST MORE THAN 20 PERCENT OF ITS CROSS-SECTIONAL AREA SHALL BE REPLACED AND CALLED TO THE ATTENTION OF THE HARBORS DIVISION CONSTRUCTION ENGINEER.
- ALL WELDING SHALL CONFORM TO AWS D1.4.
- ALL EXISTING BARS WITH CARBON EQUIVALENT (C.E.) ABOVE 0.55 PERCENT SHALL BE PREHEATED ACCORDING TO THE REQUIREMENTS SET FORTH IN AWS D.1. IF THE C.E. IS UNKNOWN, MAXIMUM PREHEAT REQUIREMENTS, FOR AN ASSUMED C.E. GREATER THAN 0.75 PERCENT SHALL BE USED.
- THE PATCH AREA SHALL BE CLEANED OF ALL DUST AND DEBRIS JUST PRIOR TO PATCHING WITH HIGH PRESSURE, OIL-FREE COMPRESSED AIR WITH APPROPRIATE PPE'S AND CONTAINMENT.

APPLICATION OF SPALL REPAIR MATERIALS:

- ALL EXPOSED STEEL IN THE REPAIR AREA SHALL BE LIBERALLY COATED WITH ANTI-CORROSION COATING PER MANUFACTURER'S RECOMMENDATIONS.
- PRIOR TO PLACEMENT OF REPAIR CONCRETE, ALL CONCRETE REPAIR SURFACES SHALL BE WASHED WITH CLEAN POTABLE WATER AND THE EXPOSED CONCRETE SURFACE SHALL BE SATURATED WITH NO WATER ACCUMULATION ON THE SURFACE.
- ALL VERTICAL AND OVERHEAD REPAIRS GREATER THAN 10 SQUARE FEET SHALL BE FORMED.
- THE CONTRACTOR SHALL NOT SECURE FORMS BY RAMSETTING. ALL HOLES AND SPALLS CAUSED BY TEMPORARY ATTACHMENTS SHALL BE PATCHED. ALL INSERTS SHALL BE REMOVED OR SHALL BE STAINLESS STEEL WITH MINIMUM $\frac{3}{4}$ INCH. COVER AFTER FORM REMOVAL.
- PATCHING COMPOUND MAY BE USED INSTEAD OF FORMED CONCRETE FOR VERTICAL AND OVERHEAD REPAIRS LESS THAN OR EQUAL TO 10 SQUARE FEET IN AREA. A SLURRY COAT OF THE COMPOUND SHALL BE USED TO PRIME THE SUBSTRATE AND THE MATERIAL SHALL BE APPLIED IN LIFTS PER MANUFACTURER'S RECOMMENDATIONS.
- SNAP TIES AND OTHER NON-REMOVABLE INSERTS SHALL BE PLASTIC OR STAINLESS STEEL.
- WITH THE EXCEPTION OF THE TOP SURFACE OF THE PIER AND FRONT FACE OF THE OUTBOARD FASCIA BEAM, ALL FORMED CONCRETE REPAIRS SHALL BE BUILT UP TO OR BEYOND THE ORIGINAL SURFACE AND SHALL MAINTAIN A 3 INCH MINIMUM CLEAR COVER FOR REINFORCING.
- CONCRETE REPAIRS AT THE TOP SURFACE OF THE PIER AND FRONT FACE OF THE OUTBOARD FASCIA BEAM SHALL BE BUILT UP TO THE ORIGINAL CONCRETE SURFACE.
- CONCRETE REPAIRS SHALL MATCH AND MAINTAIN EXISTING CHAMFER EDGES AND EXPANSION JOINTS. CONTRACTOR SHALL INSTALL JOINT FILLER TO MAINTAIN JOINTS.
- REPAIR CONCRETE SHALL BE VIBRATED, RODDED OR TAMPED DURING PLACEMENT TO CONSOLIDATE THE POUR AND FILL ALL CORNERS OF THE PATCH OR FORM AND BENEATH THE REINFORCING.
- THERE SHALL BE NO COLD JOINTS IN THE FIELD OF THE REPAIR.
- THE REPAIRED SURFACE FINISH SHALL MATCH THE ORIGINAL SURFACE FINISH.
- VOID SPACES BEYOND THE EDGE OF THE FORM SHALL BE DRY PACKED IN LIFTS WITH PATCHING COMPOUND.
- FORMWORK FOR CONCRETE REPAIRS ON THE PIER SUBSTRUCTURE SHALL NOT BE REMOVED FOR A MINIMUM OF 24 HOURS AND UNTIL CONCRETE HAS OBTAINED A MINIMUM COMPRESSIVE STRENGTH OF 4,000 PSI.
- CONCRETE REPAIRS ON THE UNDERSIDE OF THE PIER SHALL BE CURED EITHER BY LEAVING FORMS IN PLACE A MINIMUM OF 7 DAYS OR COVERING THE SURFACE WITH A CURING COMPOUND APPROVED BY THE HARBORS DIVISION CONSTRUCTION ENGINEER.

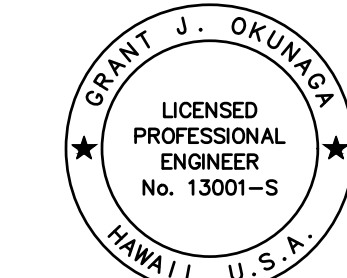
 <p>THIS WORK WAS PREPARED BY ME OR UNDER MY SUPERVISION <i>Grant Okuniga</i> MKE ASSOCIATES LLC</p>	REVISION	DATE	DESCRIPTION	BY	APPROVED
	STATE OF HAWAII DEPARTMENT OF TRANSPORTATION HARBORS DIVISION				
	JOB TITLE SUBSTRUCTURE REPAIRS AT PIERS 16 AND 17 HONOLULU HARBOR, OAHU, HAWAII				
	SHEET TITLE STRUCTURAL NOTES				
DESIGNED BY: GO	JOB NUMBER			SHEET	
DRAWN BY: DL	S10852			S-1	
CHECKED BY: GM	DATE: 04/2023			SCALE: AS SHOWN	
					3 of 14 SHTS.

Drawing Date: 04/27/2023 11:42 AM

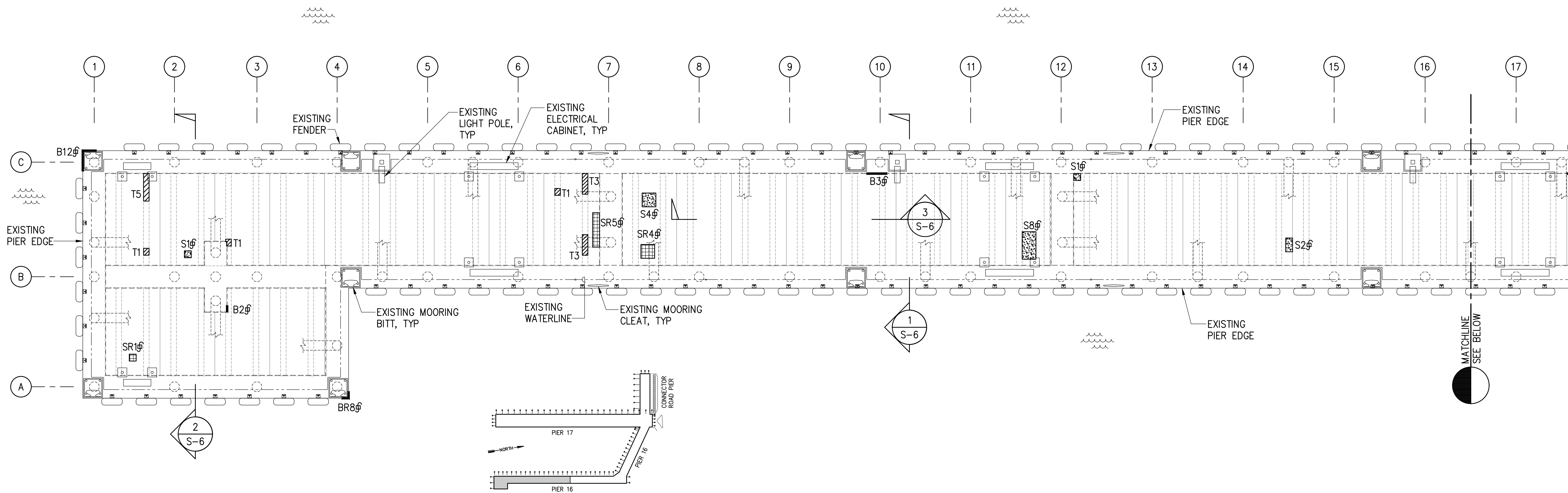

KEY PLAN

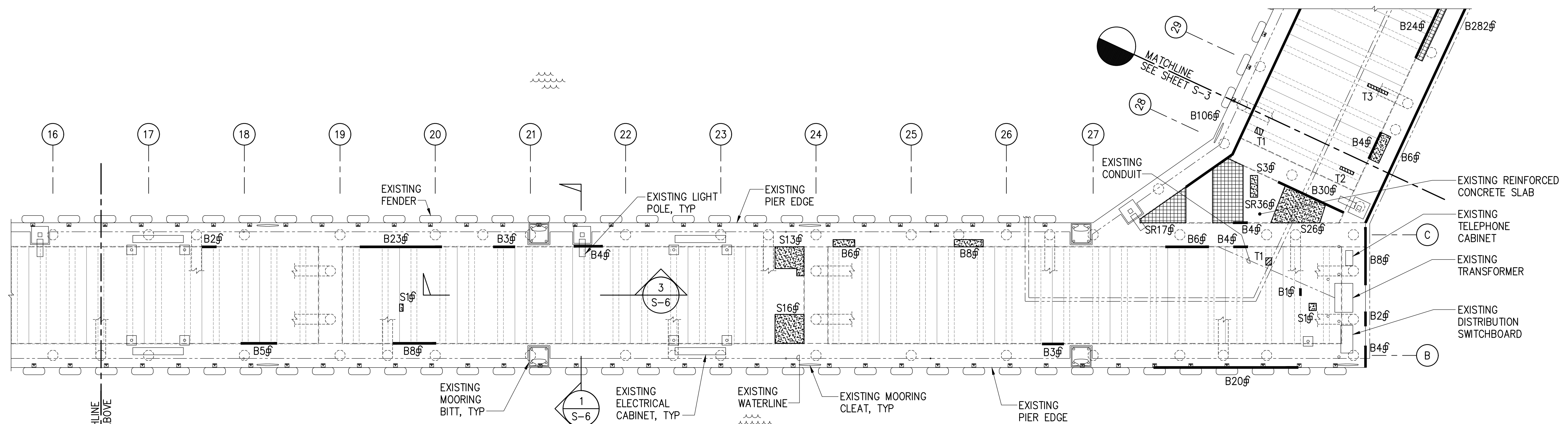

KEY PLAN

- SPALL REPAIR LEGEND:**
- SLAB SOFFIT SPALL (TYPE S), SEE DETAIL 1/S-8
 - SLAB SOFFIT SPALL WITH REINFORCING THAT HAS LOST MORE THAN 20% OF ITS CROSS-SECTIONAL AREA (TYPE SR), SEE DETAIL 2/S-8
 - VERTICAL SURFACE SPALL ON BEAM (TYPE B OR BR), SEE DETAILS 1/S-9 AND 2/S-9
 - BEAM SOFFIT SPALL REPAIR (TYPE B), SEE DETAIL 1/S-9
 - BEAM SOFFIT SPALL WITH REINFORCING THAT HAS LOST MORE THAN 20% OF ITS CROSS-SECTIONAL AREA (TYPE BR), SEE DETAIL 2/S-9
 - PRECAST TEE BEAM SPALL (TYPE T), SEE DETAIL 1/S-10
 - PRECAST PLANK SOFFIT SPALL REPAIR (TYPE P), SEE DETAIL 1/S-11
 - ☐ SQUARE FEET

- NOTES:**
1. APPROX LINEAR FOOT AND SQUARE FOOT VALUES LISTED REFER TO COMPLETED REPAIR QUANTITIES.
 2. FOR PRECAST PLANK SOFFIT REPAIRS (P), FIRST VALUE INDICATES FINAL REPAIR AREA AS SHOWN WITH HATCH. SECOND VALUE IN PARENTHESIS INDICATES APPROXIMATE SPALL AREA AS SHOWN WITH HATCH.
 3. MORE UTILITIES NOT SHOWN ON PLAN.
 4. CONCRETE CURB ON PIER TOPSIDE NOT SHOWN FOR CLARITY.
 5. ADDITIONAL UTILITIES NOT SHOWN MAY BE PRESENT ON THE PIER UNDERSIDE.

PARTIAL PIER 16 PLAN
SCALE: 1/8" = 1'-0"

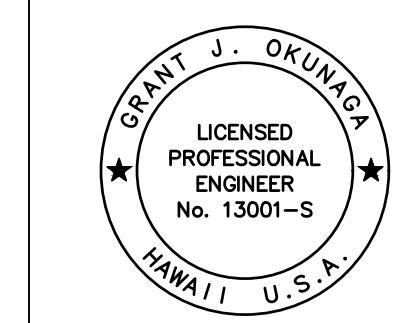
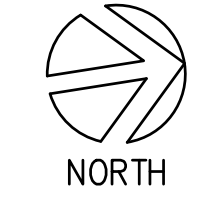

THIS WORK WAS PREPARED BY ME OR UNDER MY SUPERVISION
EXP. 4-30-24
Grant J. Okuniga
MKE ASSOCIATES LLC

REVISION	DATE	DESCRIPTION	BY	APPROVED
STATE OF HAWAII DEPARTMENT OF TRANSPORTATION HARBORS DIVISION				
JOB TITLE SUBSTRUCTURE REPAIRS AT PIERS 16 AND 17 HONOLULU HARBOR, OAHU, HAWAII				
SHEET TITLE PARTIAL PIER 16 PLAN				
DESIGNED BY: GO	JOB NUMBER			SHEET
DRAWN BY: DL	S10852			S-2
CHECKED BY: GM	DATE: 04/2023			4 of 14 SHTS.
SCALE: AS SHOWN				

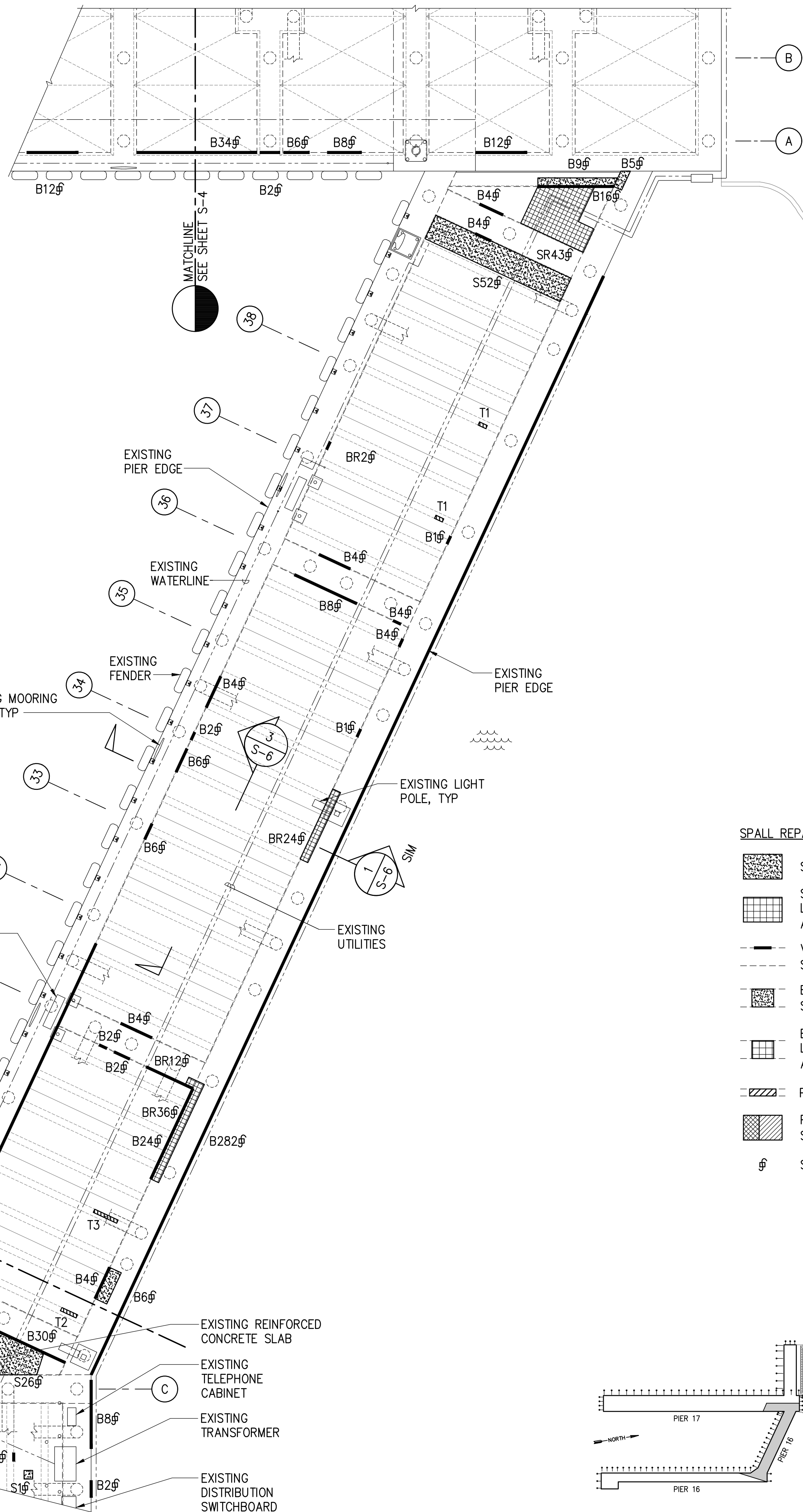

- SPALL REPAIR LEGEND:**
- SLAB SOFFIT SPALL (TYPE S), SEE DETAIL 1/S-8
 - SLAB SOFFIT SPALL WITH REINFORCING THAT HAS LOST MORE THAN 20% OF ITS CROSS-SECTIONAL AREA (TYPE SR), SEE DETAIL 2/S-8
 - VERTICAL SURFACE SPALL ON BEAM (TYPE B OR BR), SEE DETAILS 1/S-9 AND 2/S-9
 - BEAM SOFFIT SPALL REPAIR (TYPE B), SEE DETAIL 1/S-9
 - BEAM SOFFIT SPALL WITH REINFORCING THAT HAS LOST MORE THAN 20% OF ITS CROSS-SECTIONAL AREA (TYPE BR), SEE DETAIL 2/S-9
 - PRECAST TEE BEAM SPALL (TYPE T), SEE DETAIL 1/S-10
 - PRECAST PLANK SOFFIT SPALL REPAIR (TYPE P), SEE DETAIL 1/S-11
 - ⊠ SQUARE FEET

- NOTES:**
1. APPROX LINEAR FOOT AND SQUARE FOOT VALUES LISTED REFER TO COMPLETED REPAIR QUANTITIES.
 2. FOR PRECAST PLANK SOFFIT REPAIRS (P), FIRST VALUE INDICATES FINAL REPAIR AREA AS SHOWN WITH HATCH. SECOND VALUE IN PARENTHESIS INDICATES APPROXIMATE SPALL AREA AS SHOWN WITH HATCH.
 3. MORE UTILITIES NOT SHOWN ON PLAN.
 4. CONCRETE CURB ON PIER TOPSIDE NOT SHOWN FOR CLARITY.
 5. ADDITIONAL UTILITIES NOT SHOWN MAY BE PRESENT ON THE PIER UNDERSIDE.

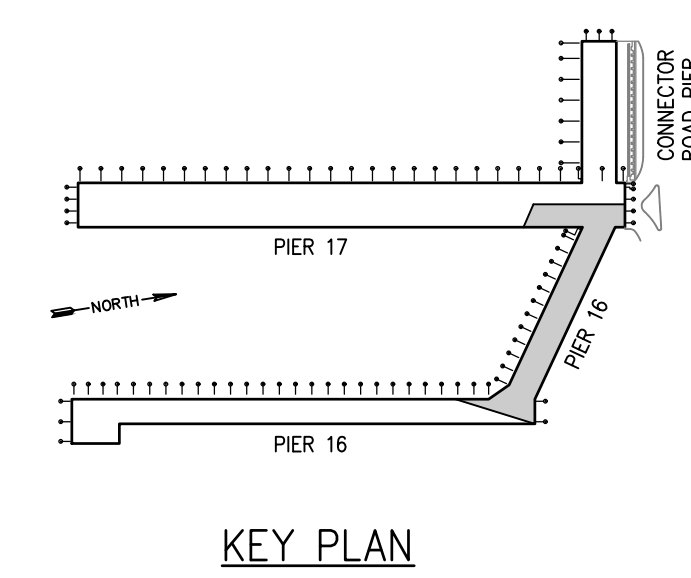

PARTIAL PIER 16 PLAN
 SCALE: 1/8" = 1'-0"
 NORTH

THIS WORK WAS PREPARED BY ME OR UNDER MY SUPERVISION
 EXP. 4-30-24
Grant J. Okunaga
 MKE ASSOCIATES LLC

REVISION	DATE	DESCRIPTION	BY	APPROVED
STATE OF HAWAII DEPARTMENT OF TRANSPORTATION HARBORS DIVISION				
JOB TITLE SUBSTRUCTURE REPAIRS AT PIERS 16 AND 17 HONOLULU HARBOR, OAHU, HAWAII				
SHEET TITLE PARTIAL PIER 16 PLAN				
DESIGNED BY: GO				SHEET S-3
DRAWN BY: DL				JOB NUMBER S10852
CHECKED BY: GM				
DATE: 04/2023				
SCALE: AS SHOWN				5 of 14 SHTS.

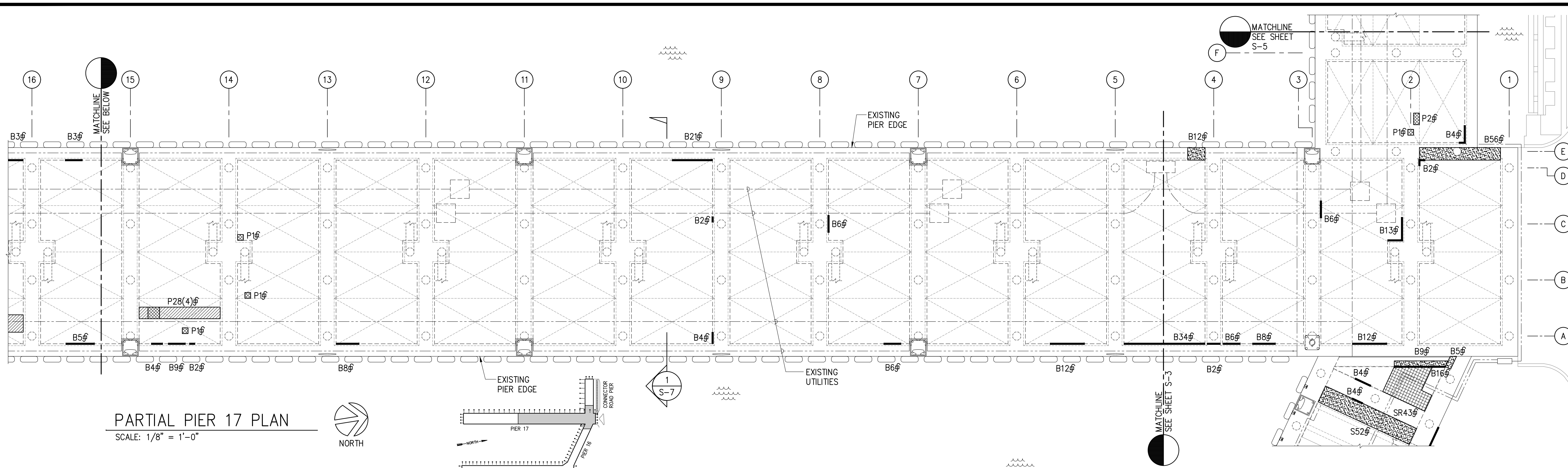

PARTIAL PIER 17 PLAN
SCALE: 1/8" = 1'-0"

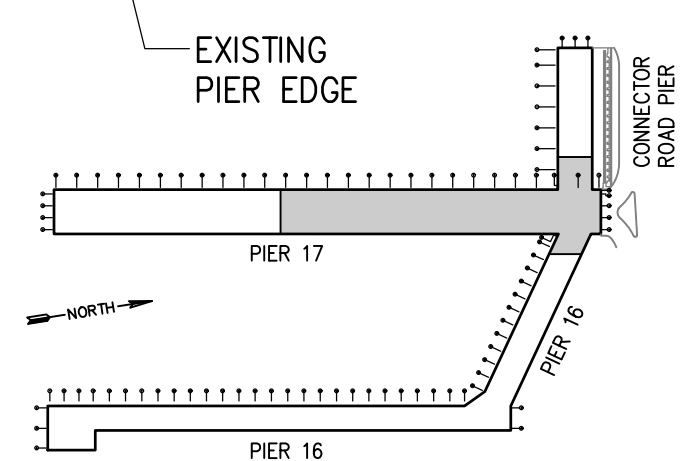

KEY PLAN

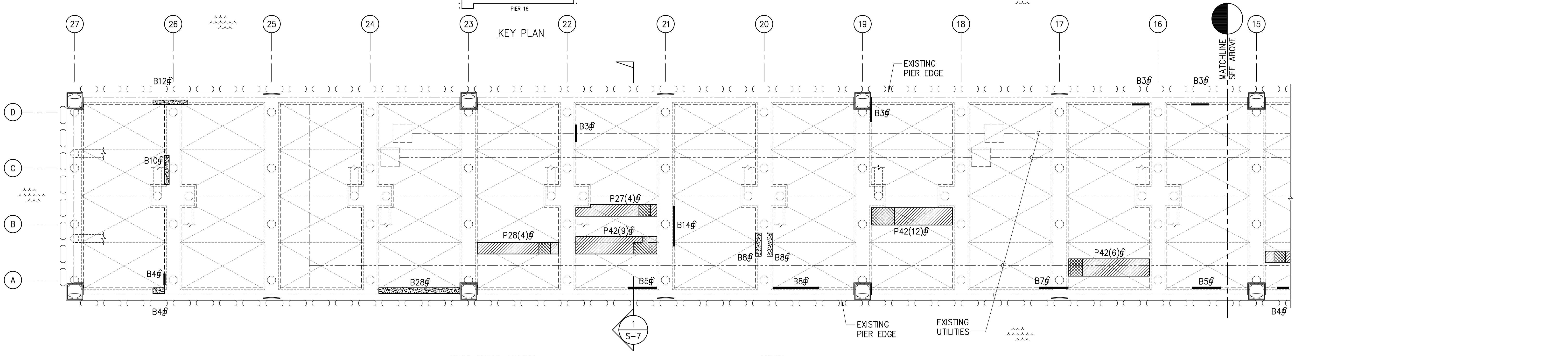

PARTIAL PIER 17 PLAN
SCALE: 1/8" = 1'-0"

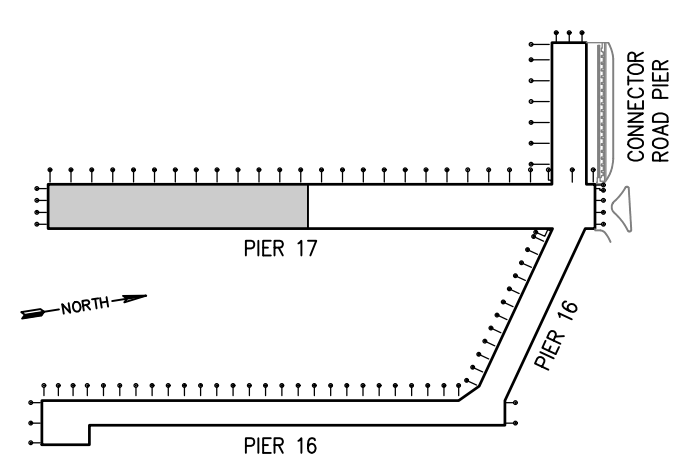
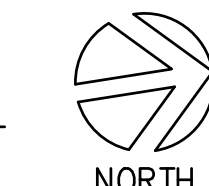

KEY PLAN

- SPALL REPAIR LEGEND:**
- SLAB SOFFIT SPALL (TYPE S), SEE DETAIL 1/S-8
 - SLAB SOFFIT SPALL WITH REINFORCING THAT HAS LOST MORE THAN 20% OF ITS CROSS-SECTIONAL AREA (TYPE SR), SEE DETAIL 2/S-8
 - VERTICAL SURFACE SPALL ON BEAM (TYPE B OR BR), SEE DETAILS 1/S-9 AND 2/S-9
 - BEAM SOFFIT SPALL REPAIR (TYPE B), SEE DETAIL 1/S-9
 - BEAM SOFFIT SPALL WITH REINFORCING THAT HAS LOST MORE THAN 20% OF ITS CROSS-SECTIONAL AREA (TYPE BR), SEE DETAIL 2/S-9
 - PRECAST TEE BEAM SPALL (TYPE T), SEE DETAIL 1/S-10
 - PRECAST PLANK SOFFIT SPALL REPAIR (TYPE P), SEE DETAIL 1/S-11
 - SQUARE FEET

- NOTES:**
1. APPROX LINEAR FOOT AND SQUARE FOOT VALUES LISTED REFER TO COMPLETED REPAIR QUANTITIES.
 2. FOR PRECAST PLANK SOFFIT REPAIRS (P), FIRST VALUE INDICATES FINAL REPAIR AREA AS SHOWN WITH HATCH. SECOND VALUE IN PARENTHESIS INDICATES APPROXIMATE SPALL AREA AS SHOWN WITH HATCH.
 3. MORE UTILITIES NOT SHOWN ON PLAN.
 4. CONCRETE CURB ON PIER TOPSIDE NOT SHOWN FOR CLARITY.
 5. ADDITIONAL UTILITIES NOT SHOWN MAY BE PRESENT ON THE PIER UNDERSIDE.

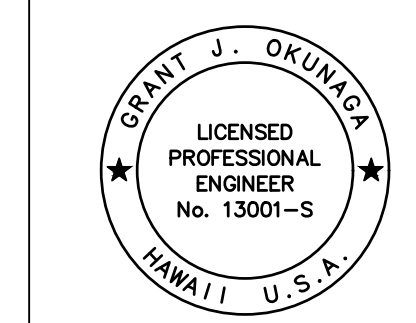

THIS WORK WAS PREPARED BY ME OR UNDER MY SUPERVISION
 EXP. 4-30-24
Grant J. Okuniga
 MKE ASSOCIATES LLC

REVISION	DATE	DESCRIPTION	BY	APPROVED
STATE OF HAWAII DEPARTMENT OF TRANSPORTATION HARBORS DIVISION				
JOB TITLE SUBSTRUCTURE REPAIRS AT PIERS 16 AND 17 HONOLULU HARBOR, OAHU, HAWAII				
SHEET TITLE PARTIAL PIER 17 PLAN				
DESIGNED BY: GO	JOB NUMBER		SHEET	
DRAWN BY: DL	S10852		S-4	
CHECKED BY: GM	DATE: 04/2023		6 of 14 SHTS.	
SCALE: AS SHOWN				

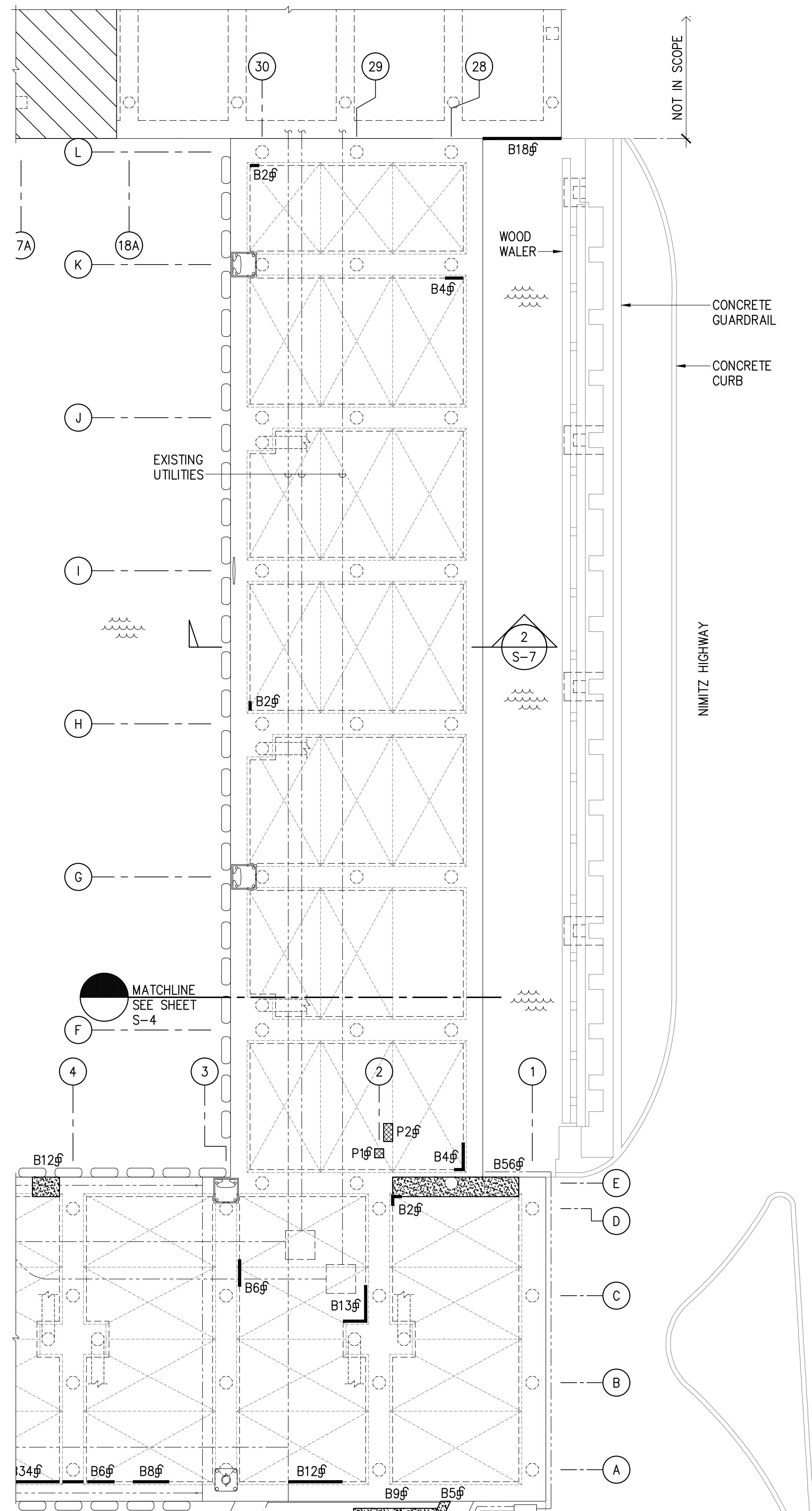

SPALL REPAIR LEGEND:

- SLAB SOFFIT SPALL (TYPE S), SEE DETAIL 1/S-8
- SLAB SOFFIT SPALL WITH REINFORCING THAT HAS LOST MORE THAN 20% OF ITS CROSS-SECTIONAL AREA (TYPE SR), SEE DETAIL 2/S-8
- VERTICAL SURFACE SPALL ON BEAM (TYPE B OR BR), SEE DETAILS 1/S-9 AND 2/S-9
- BEAM SOFFIT SPALL REPAIR (TYPE B), SEE DETAIL 1/S-9
- BEAM SOFFIT SPALL WITH REINFORCING THAT HAS LOST MORE THAN 20% OF ITS CROSS-SECTIONAL AREA (TYPE BR), SEE DETAIL 2/S-9
- PRECAST TEE BEAM SPALL (TYPE T), SEE DETAIL 1/S-10
- PRECAST PLANK SOFFIT SPALL REPAIR (TYPE P), SEE DETAIL 1/S-11
- SQUARE FEET

NOTES:

1. APPROX LINEAR FOOT AND SQUARE FOOT VALUES LISTED REFER TO COMPLETED REPAIR QUANTITIES.
2. FOR PRECAST PLANK SOFFIT REPAIRS (P), FIRST VALUE INDICATES FINAL REPAIR AREA AS SHOWN WITH HATCH. SECOND VALUE IN PARENTHESIS INDICATES APPROXIMATE SPALL AREA AS SHOWN WITH HATCH.
3. MORE UTILITIES NOT SHOWN ON PLAN.
4. CONCRETE CURB ON PIER TOPSIDE NOT SHOWN FOR CLARITY.
5. ADDITIONAL UTILITIES NOT SHOWN MAY BE PRESENT ON THE PIER UNDERSIDE.

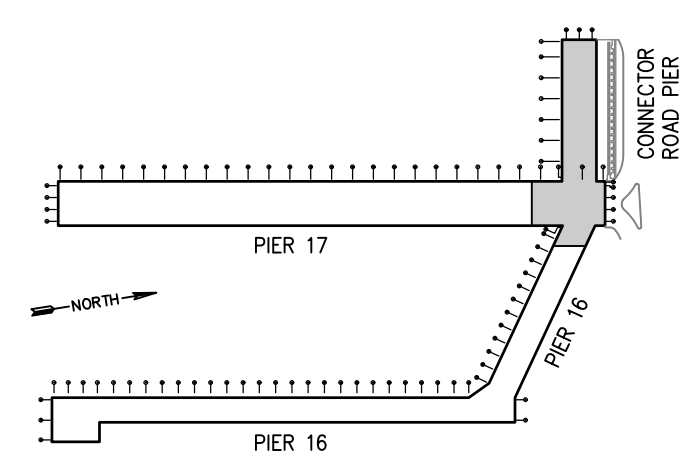

KEY PLAN

CONNECTOR ROAD - PIER PLAN
SCALE: 1/8" = 1'-0"

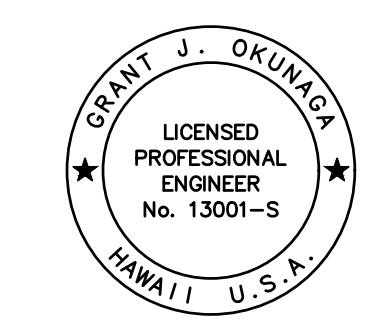
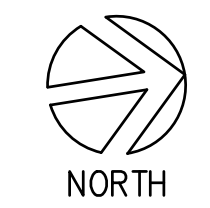

THIS WORK WAS PREPARED BY ME OR UNDER MY SUPERVISION
EXP. 4-30-24
Grant J. Okunaga
MKE ASSOCIATES LLC

REVISION	DATE	DESCRIPTION	BY	APPROVED
STATE OF HAWAII DEPARTMENT OF TRANSPORTATION HARBORS DIVISION				
JOB TITLE SUBSTRUCTURE REPAIRS AT PIERS 16 AND 17 HONOLULU HARBOR, OAHU, HAWAII				
SHEET TITLE CONNECTOR ROAD - PIER PLAN				
DESIGNED BY: GO	JOB NUMBER			SHEET
DRAWN BY: DL	S10852			S-5
CHECKED BY: GM	DATE: 04/2023			7 of 14 SHTS.
SCALE: AS SHOWN				

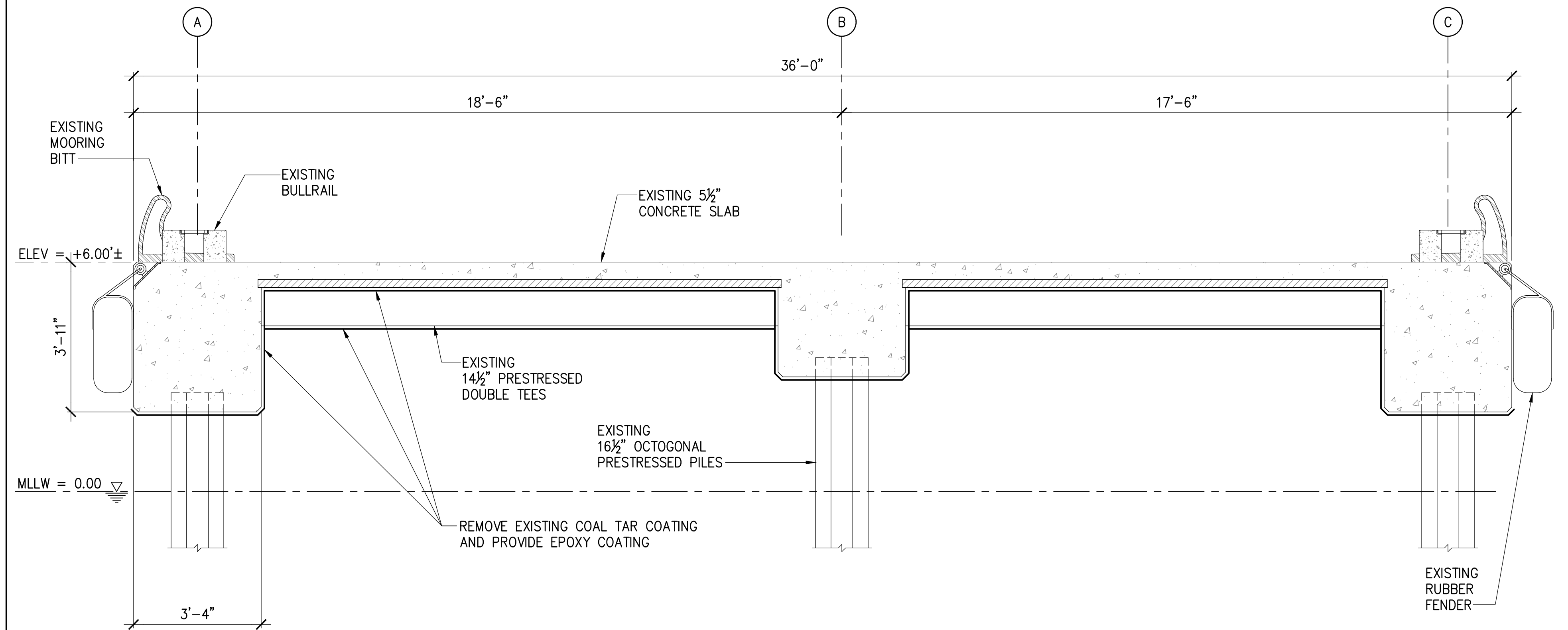
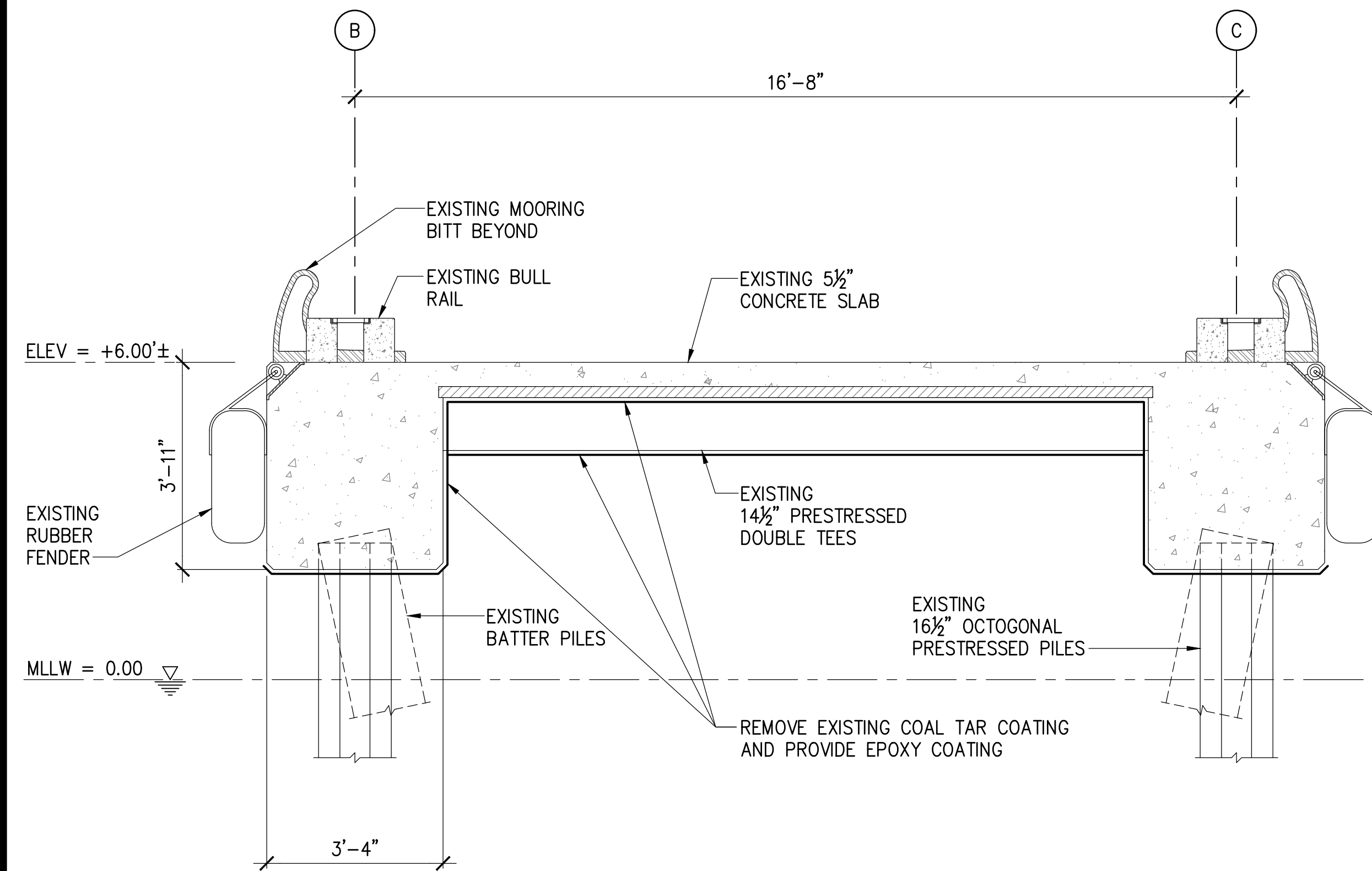

1 TYPICAL TRANSVERSE SECTION AT PIER 16
SCALE: 1/2" = 1'-0"

2 TYPICAL TRANSVERSE SECTION AT PIER 16
SCALE: 1/2" = 1'-0"

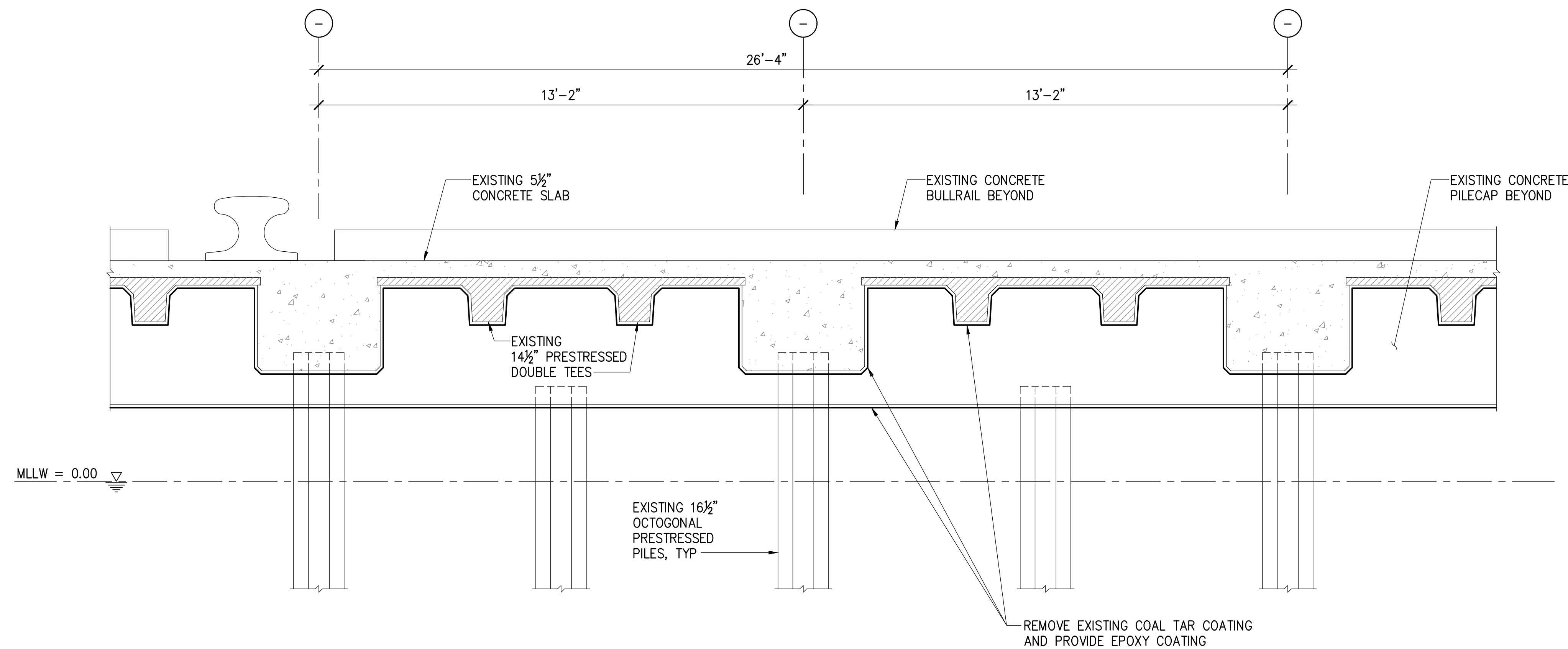

3 TYPICAL LONGITUDINAL SECTION AT PIER 16
SCALE: 1/2" = 1'-0"

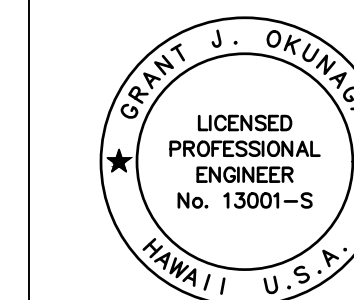

THIS WORK WAS PREPARED BY ME
OR UNDER MY SUPERVISION
EXP. 4-30-24
Grant J. Okunaka
MKE ASSOCIATES LLC

REVISION	DATE	DESCRIPTION	BY	APPROVED
STATE OF HAWAII DEPARTMENT OF TRANSPORTATION HARBORS DIVISION				
JOB TITLE SUBSTRUCTURE REPAIRS AT PIERS 16 AND 17 HONOLULU HARBOR, OAHU, HAWAII				
SHEET TITLE TYPICAL PIER SECTIONS				
DESIGNED BY: GO	JOB NUMBER S10852			SHEET S-6
DRAWN BY: DL				8 of 14 SHTS.
CHECKED BY: GM				
DATE: 04/2023				
SCALE: AS SHOWN				

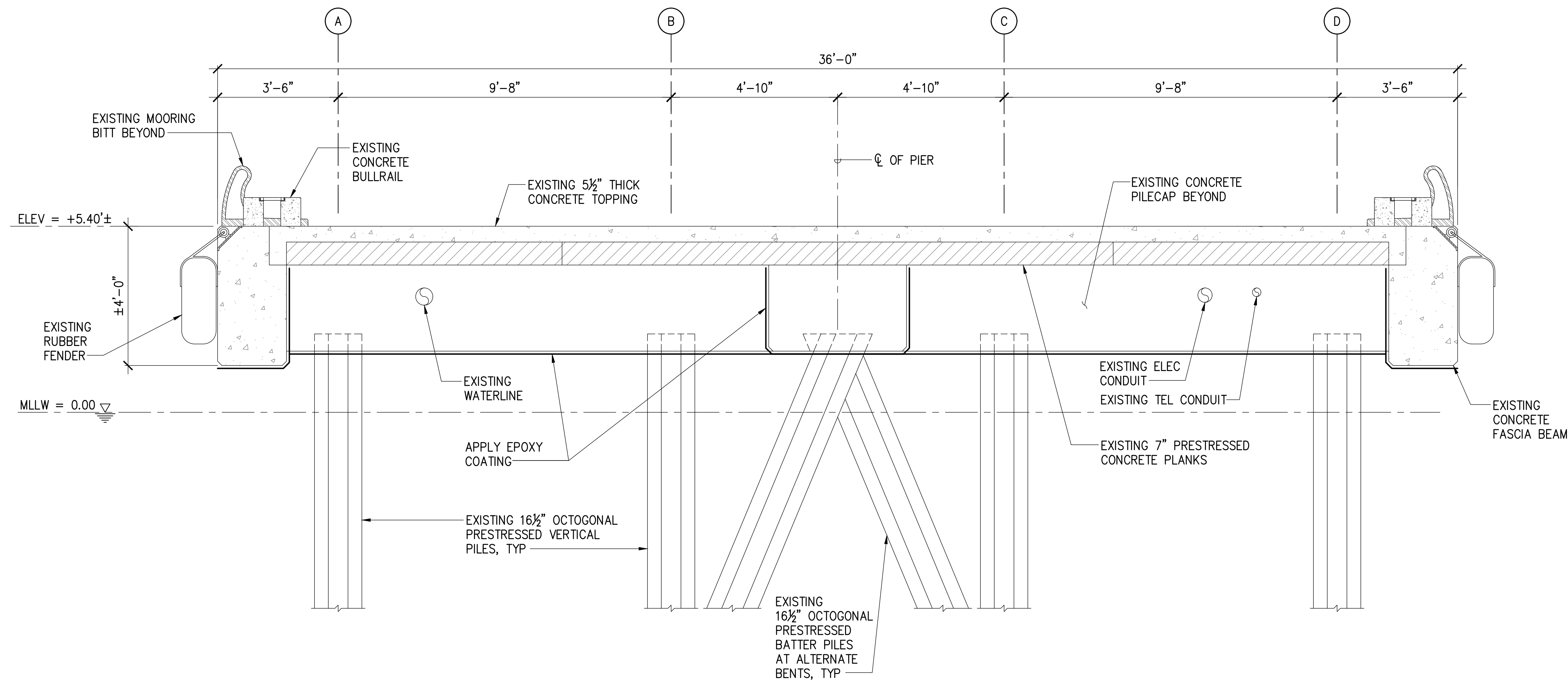

1 TYPICAL TRANSVERSE SECTION AT PIER 17
 S-7 SCALE: 1/2" = 1'-0"

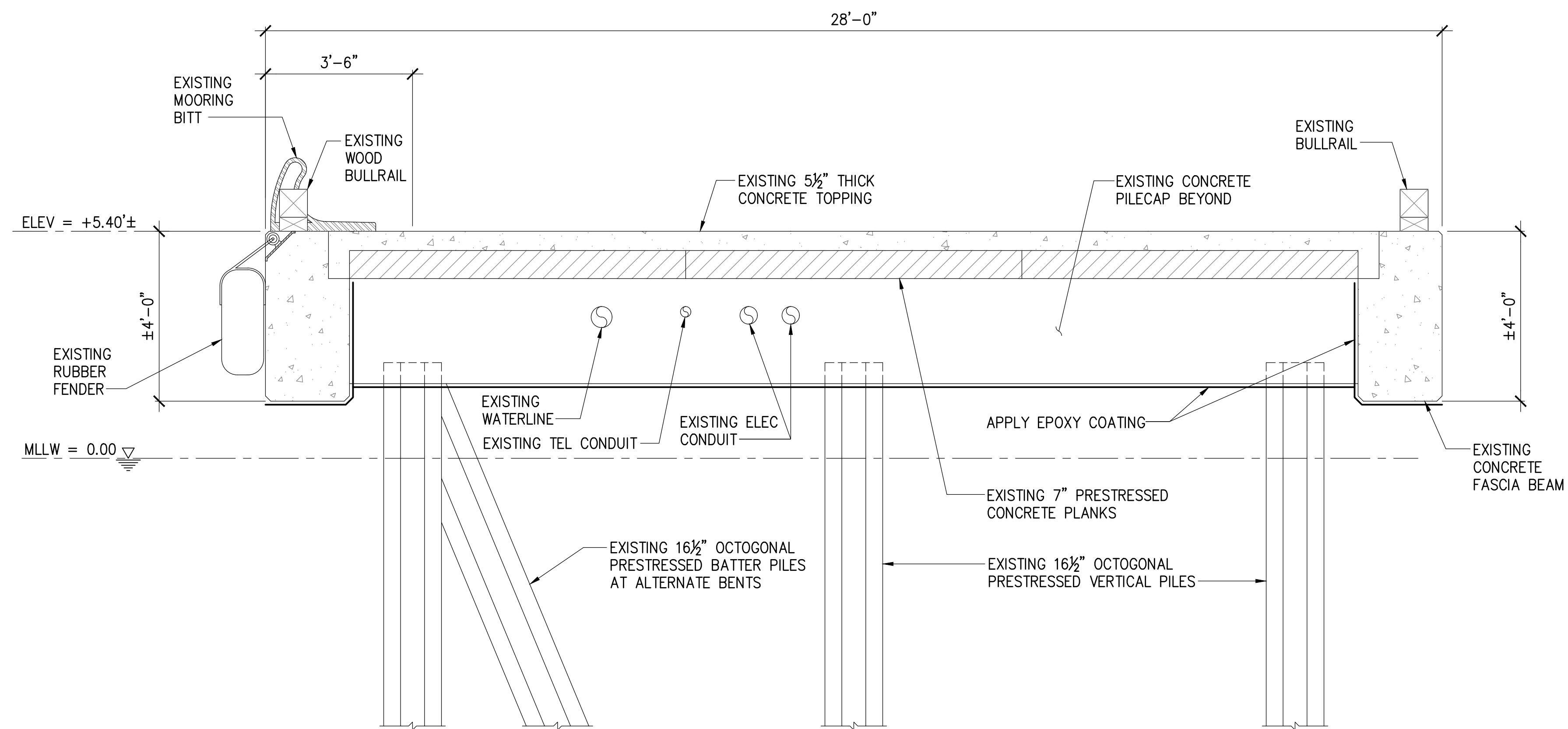

2 TYPICAL TRANSVERSE SECTION AT CONNECTOR ROAD
 S-7 SCALE: 1/2" = 1'-0"

	REVISION	DATE	DESCRIPTION	BY	APPROVED
	STATE OF HAWAII DEPARTMENT OF TRANSPORTATION HARBORS DIVISION				
	JOB TITLE SUBSTRUCTURE REPAIRS AT PIERS 16 AND 17 HONOLULU HARBOR, OAHU, HAWAII				
	SHEET TITLE TYPICAL PIER SECTIONS				
DESIGNED BY: GO		DRAWN BY: DL		SHEET S-7	
CHECKED BY: GM		DATE: 04/2023		JOB NUMBER S10852	
SCALE: AS SHOWN		MKE ASSOCIATES LLC		9 of 14 SHTS.	

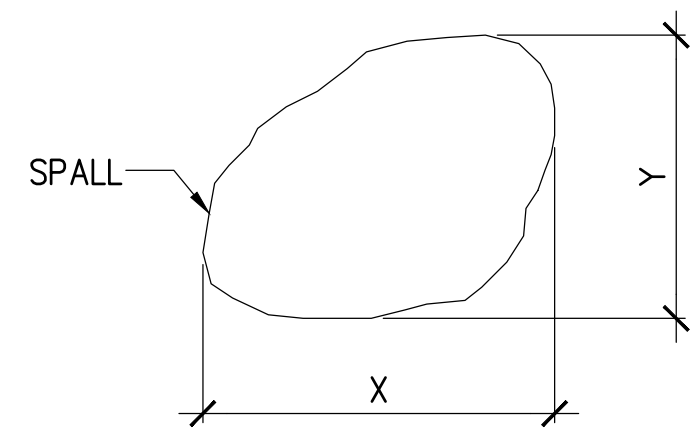

EXISTING SPALL AREA = X x Y

SOFFIT PLAN

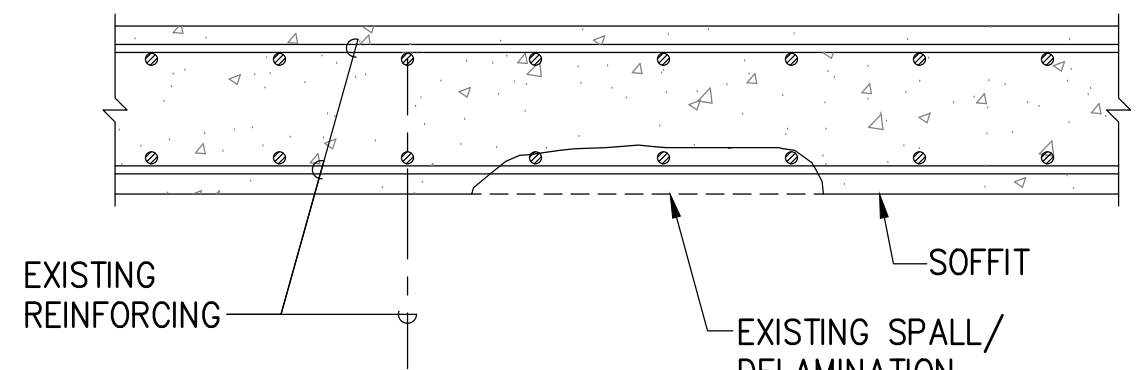

SECTION

EXISTING CONDITION

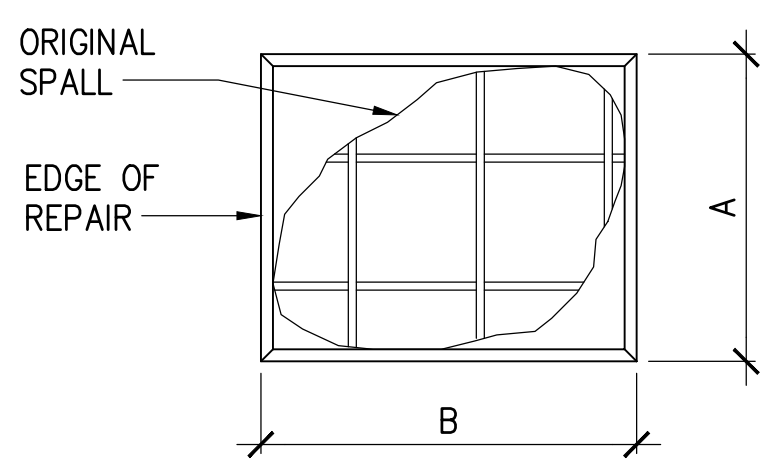

SOFFIT PLAN

REPAIRED CONDITION

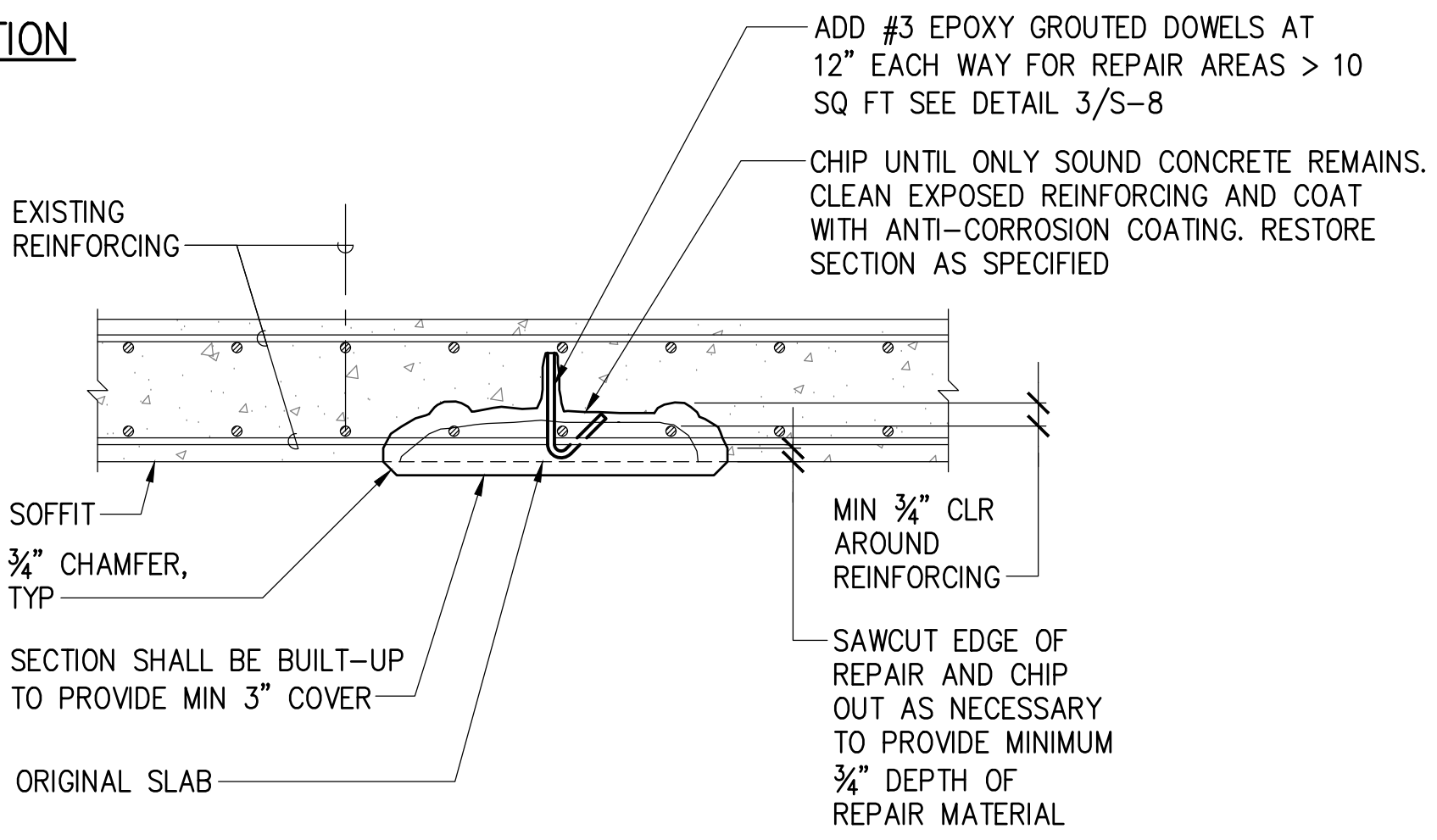

SECTION

1 SLAB SOFFIT SPALL REPAIR (TYPE S)
S-8 NOT TO SCALE

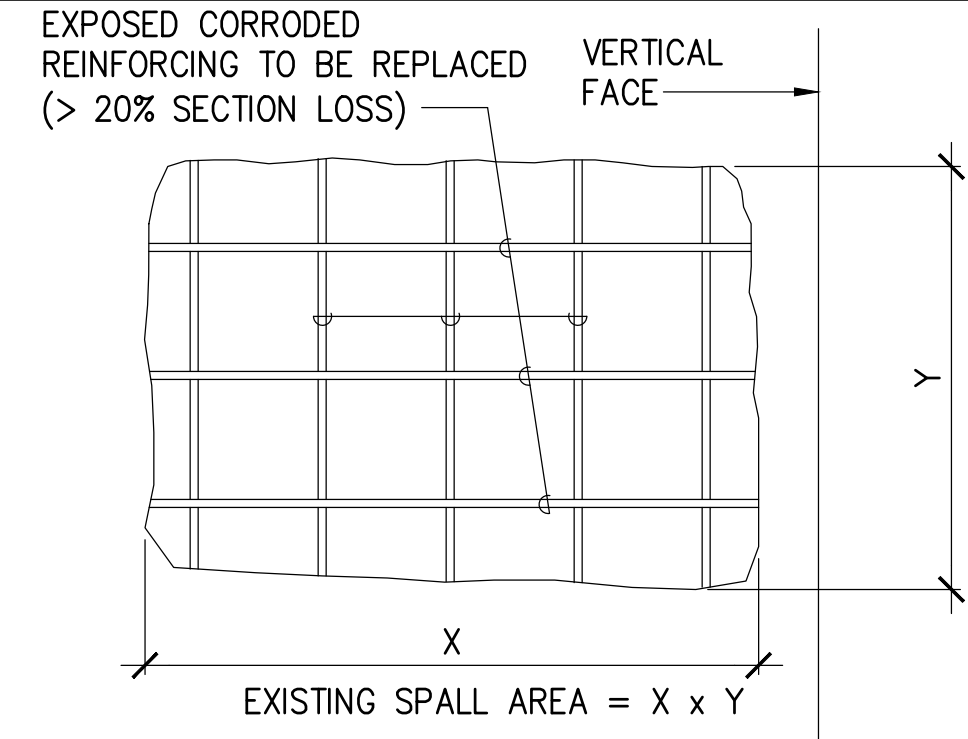

SOFFIT PLAN

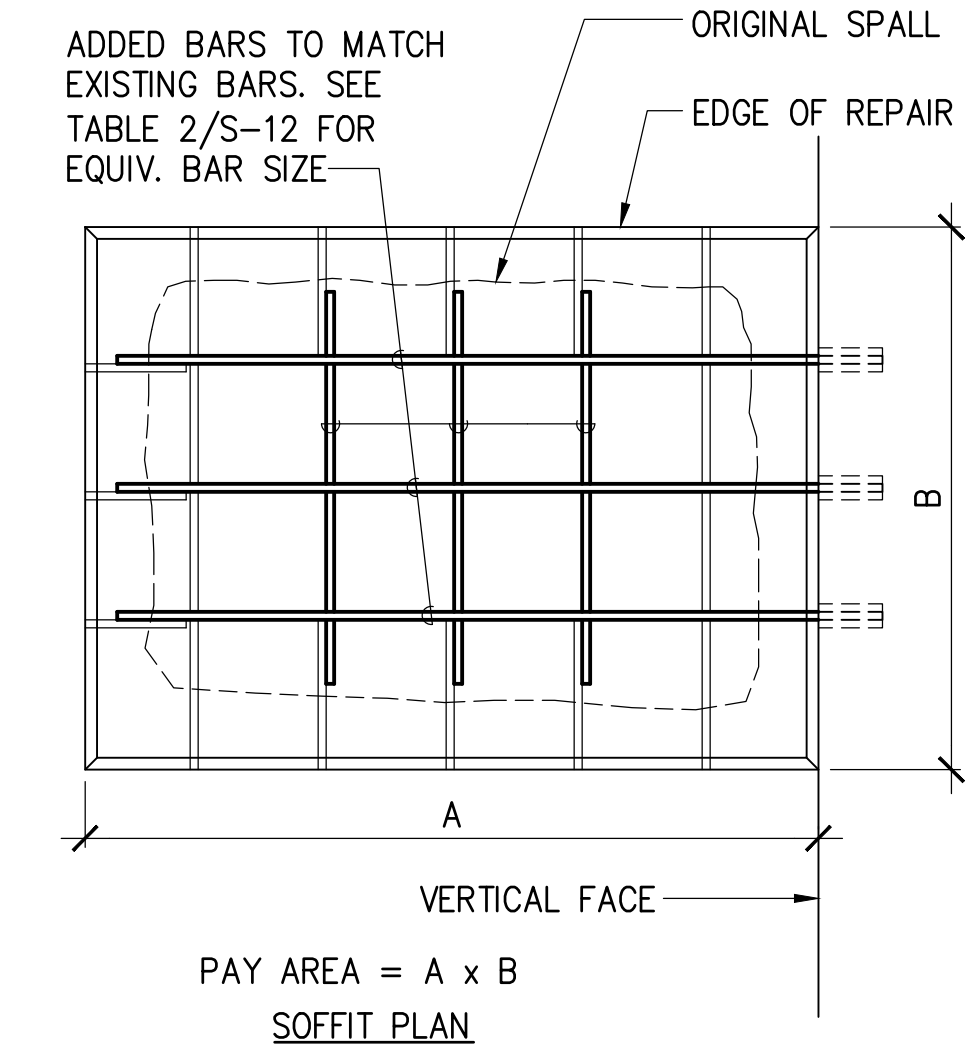

SOFFIT PLAN

2 SLAB SOFFIT SPALL REPAIR WITH REINFORCING STEEL REPLACEMENT (TYPE SR)
S-8 NOT TO SCALE

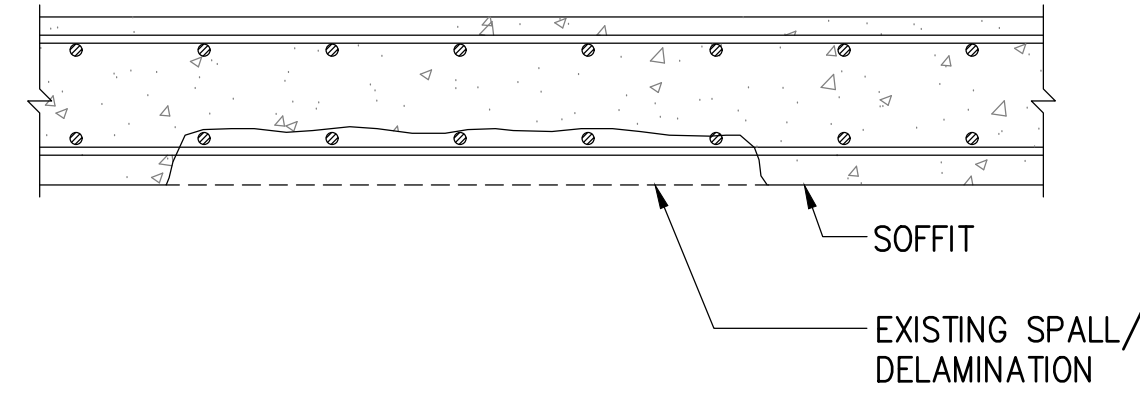

SECTION

EXISTING CONDITION

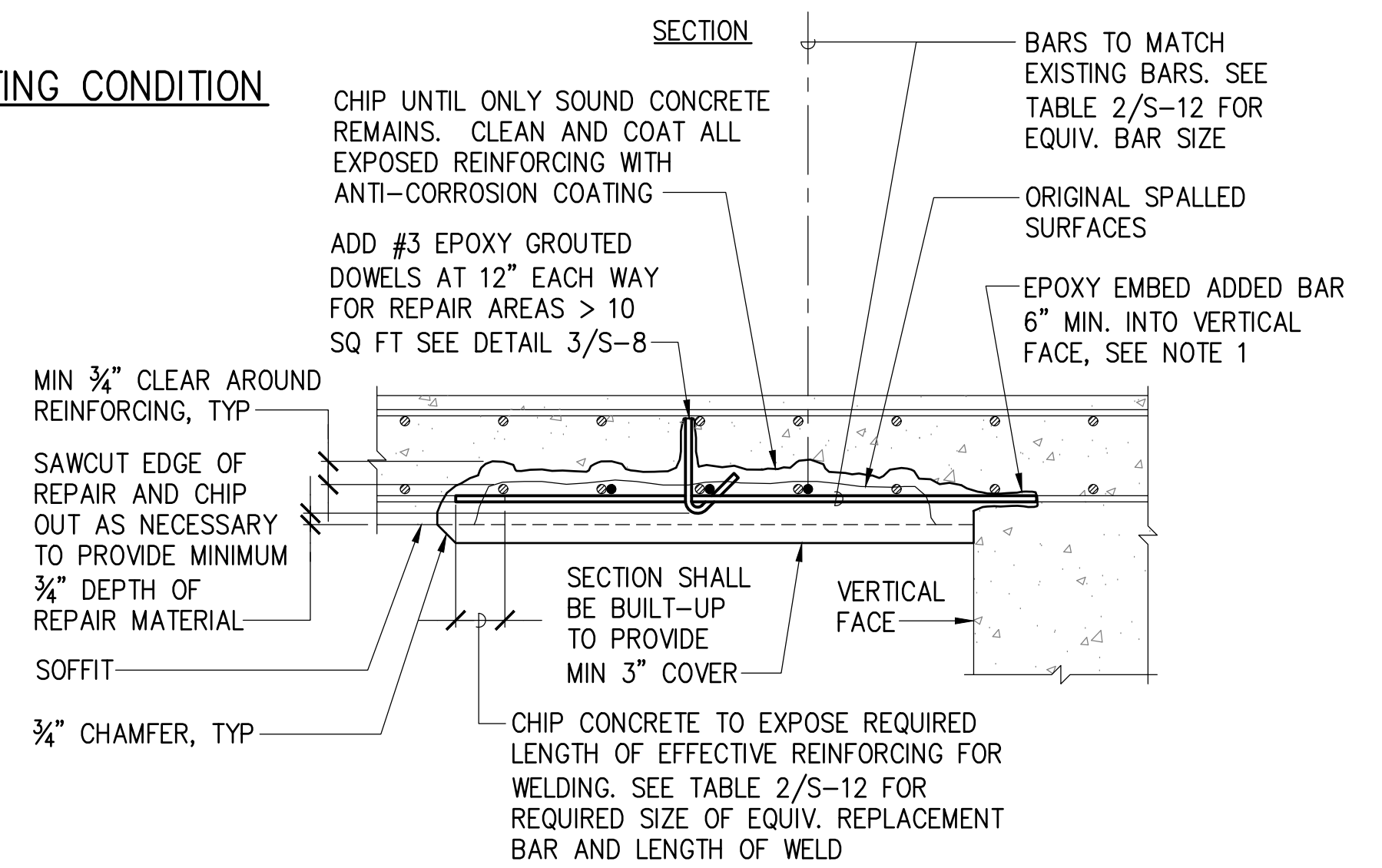

SECTION

REPAIRED CONDITION

NOTE:
1. NOTIFY CONSTRUCTION ENGINEER IF EPOXY EMBED BARS ARE LARGER THAN #5 BARS.

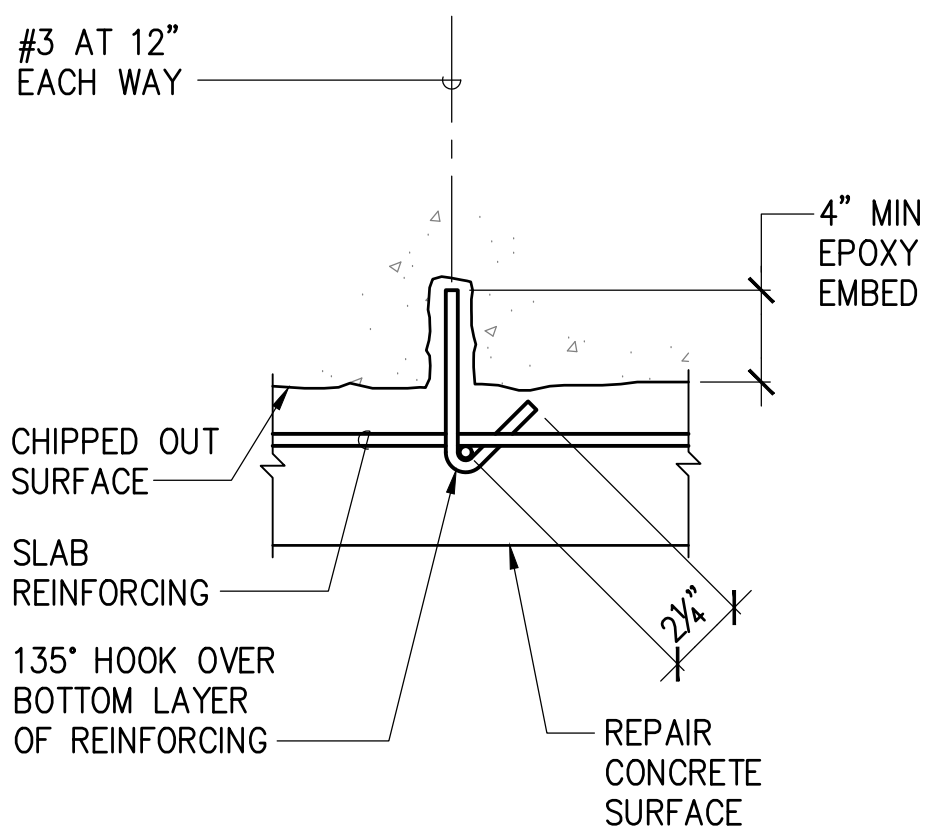

NOTE:
1. AS AN ALTERNATE TO THE #3 HOOKED REINFORCING BAR, A 3/8\"/>

3 EPOXY GROUTED DOWEL DETAIL
S-8 NOT TO SCALE

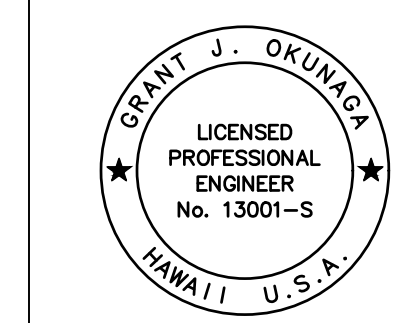

THIS WORK WAS PREPARED BY ME OR UNDER MY SUPERVISION
EXP. 4-30-24
Grant J. Okuniga
MKE ASSOCIATES LLC

REVISION	DATE	DESCRIPTION	BY	APPROVED
STATE OF HAWAII DEPARTMENT OF TRANSPORTATION HARBORS DIVISION				
JOB TITLE SUBSTRUCTURE REPAIRS AT PIERS 16 AND 17 HONOLULU HARBOR, OAHU, HAWAII				
SHEET TITLE SLAB SOFFIT AND VERTICAL SPALL REPAIR DETAILS				
DESIGNED BY: GO	JOB NUMBER			SHEET
DRAWN BY: DL	S10852			S-8
CHECKED BY: GM				
DATE: 04/2023	SCALE: AS SHOWN			10 of 14 SHTS.

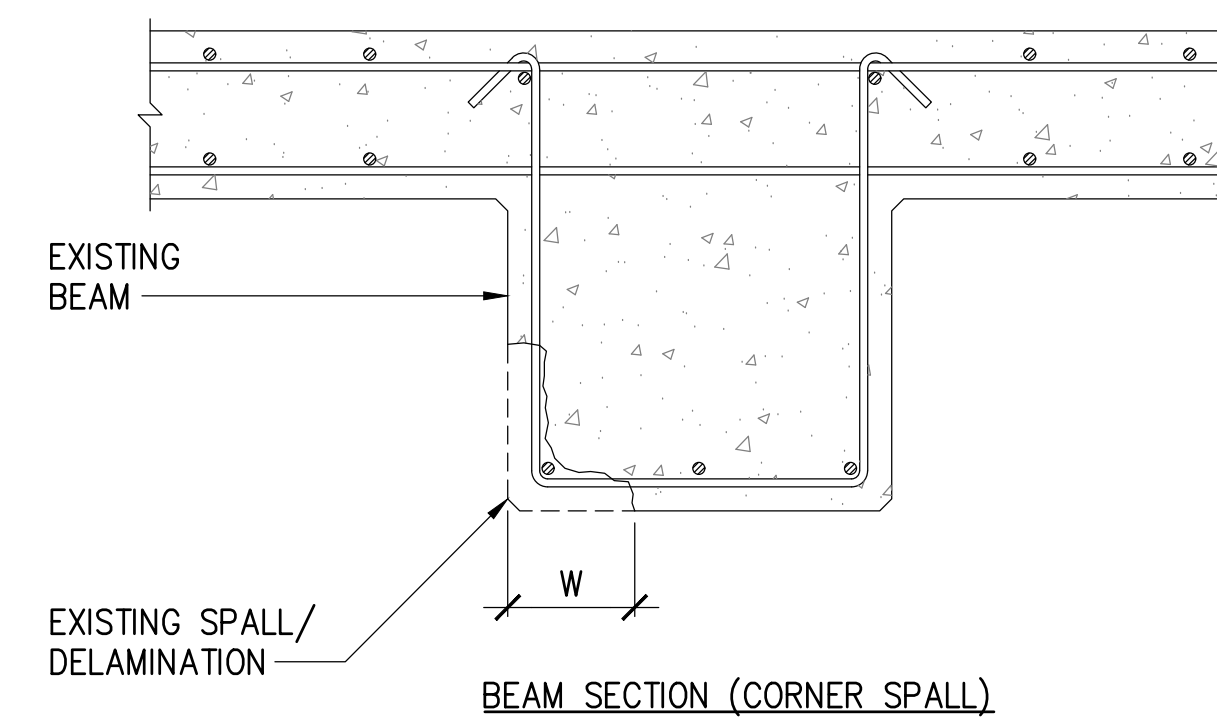
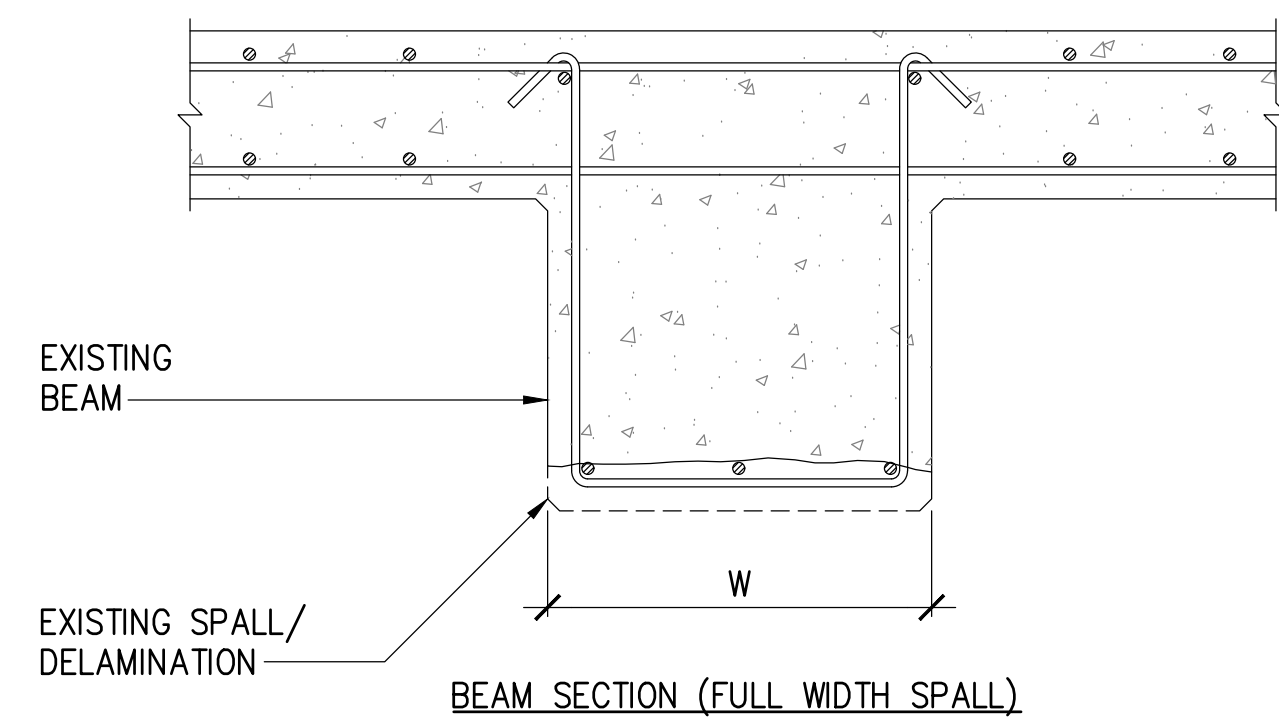
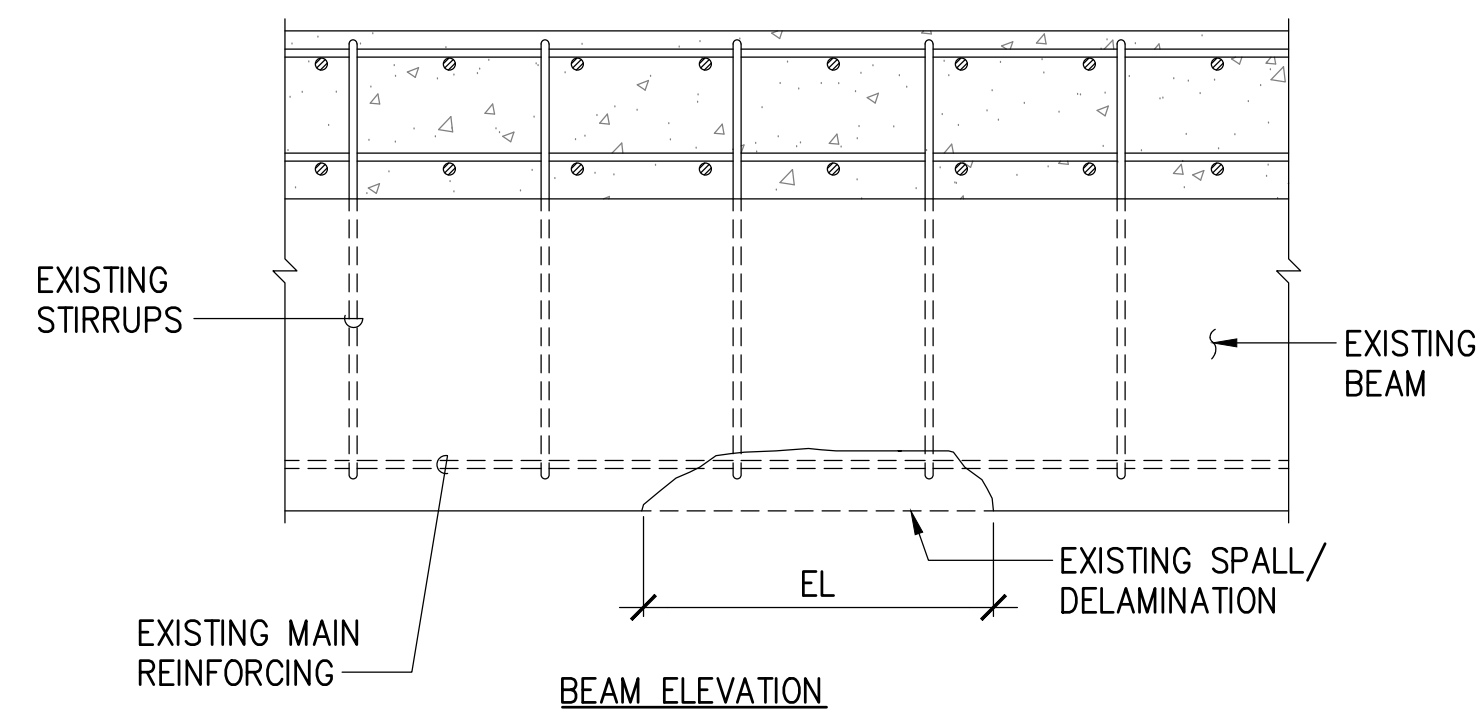

PAY AREA:
 HL = HEIGHT OF REPAIR (LEFT SIDE)
 HR = HEIGHT OF REPAIR (RIGHT SIDE)
 W = ORIGINAL WIDTH OF BEAM/GIRDER SPALL
 EL = EXISTING LENGTH OF SPALL
 NL = LENGTH OF REPAIR

PAY AREA = (HL+HR+W)NL

NOTES:

- PAY AREA SHALL BE THE TOTAL REPAIRED AREA ON ALL BEAM FACES. IF HL, HR OR W VARY ALONG THE LENGTH OF REPAIR, PAY AREA SHALL BE CALCULATED INDIVIDUALLY FOR EACH BEAM FACE.

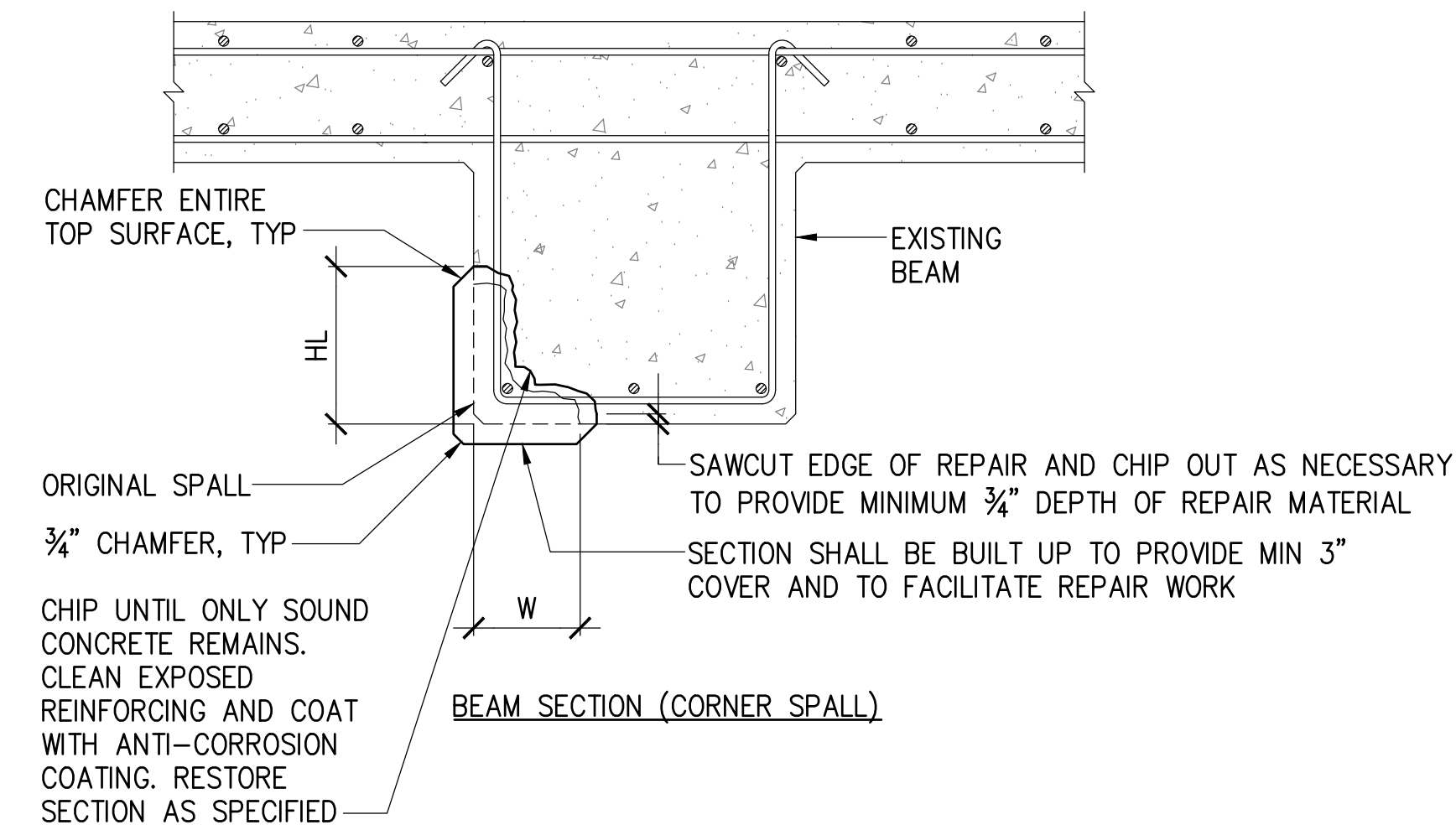
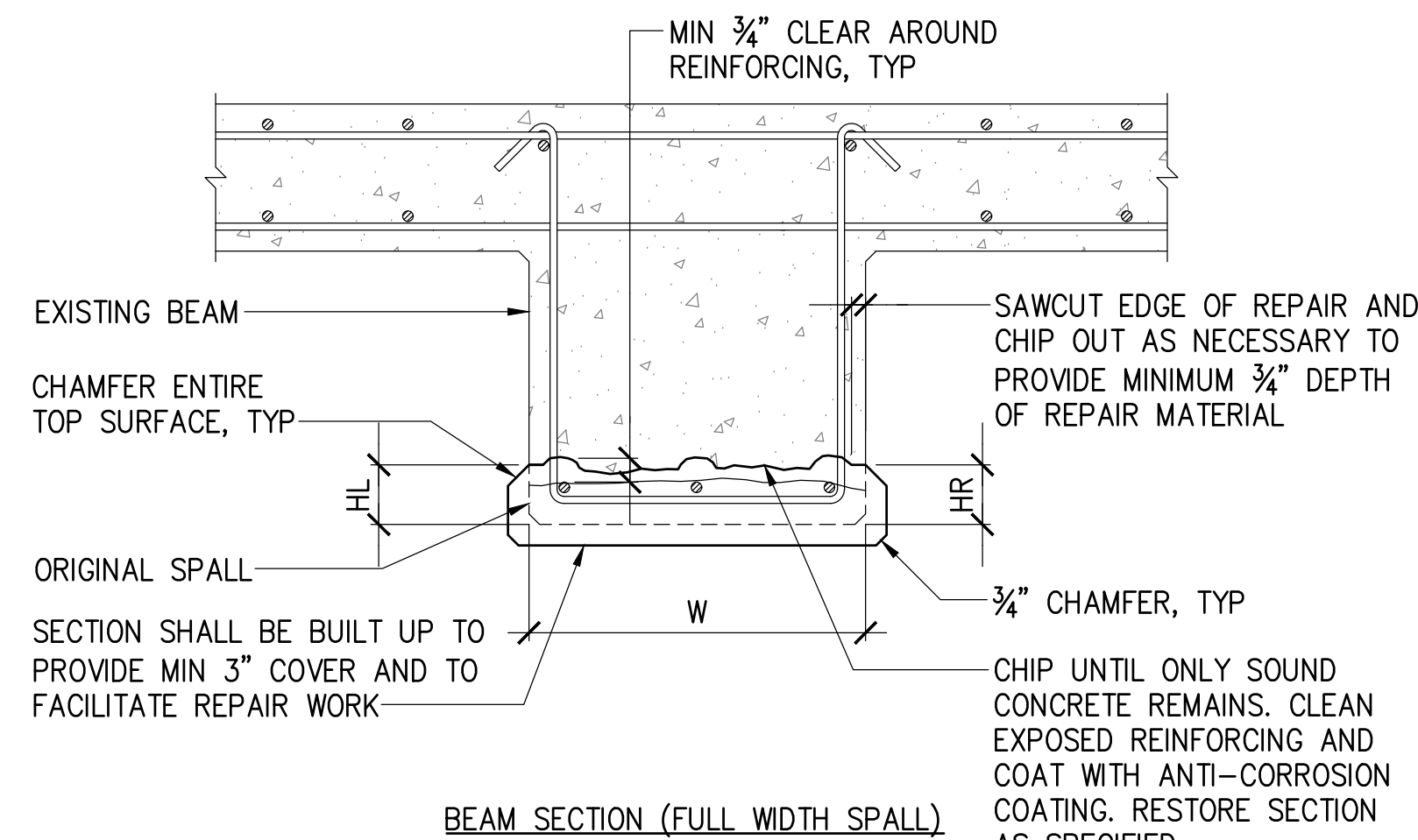
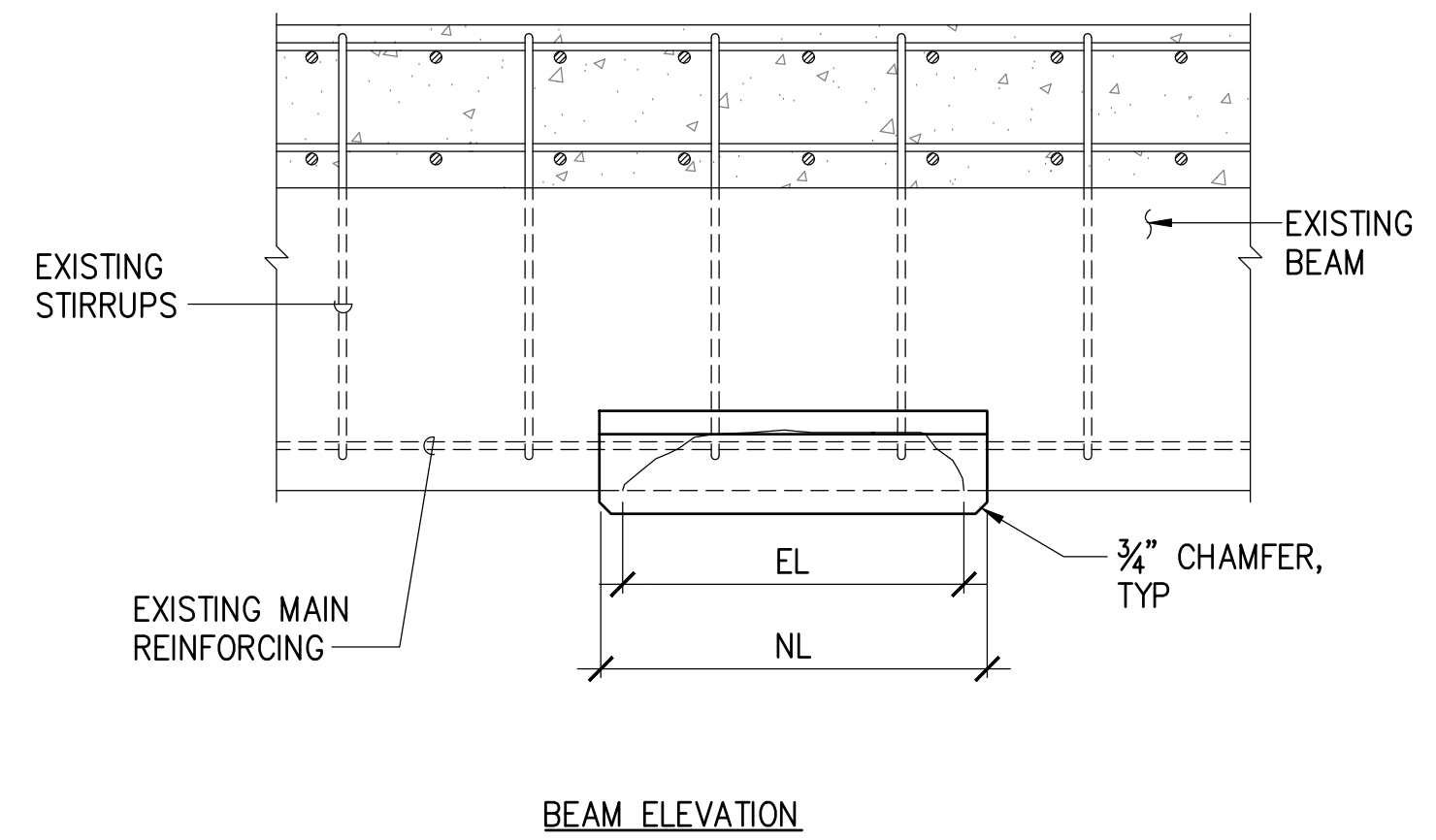

EXISTING CONDITION

REPAIRED CONDITION

1 BEAM SPALL REPAIR (TYPE B)
 S-9 NOT TO SCALE

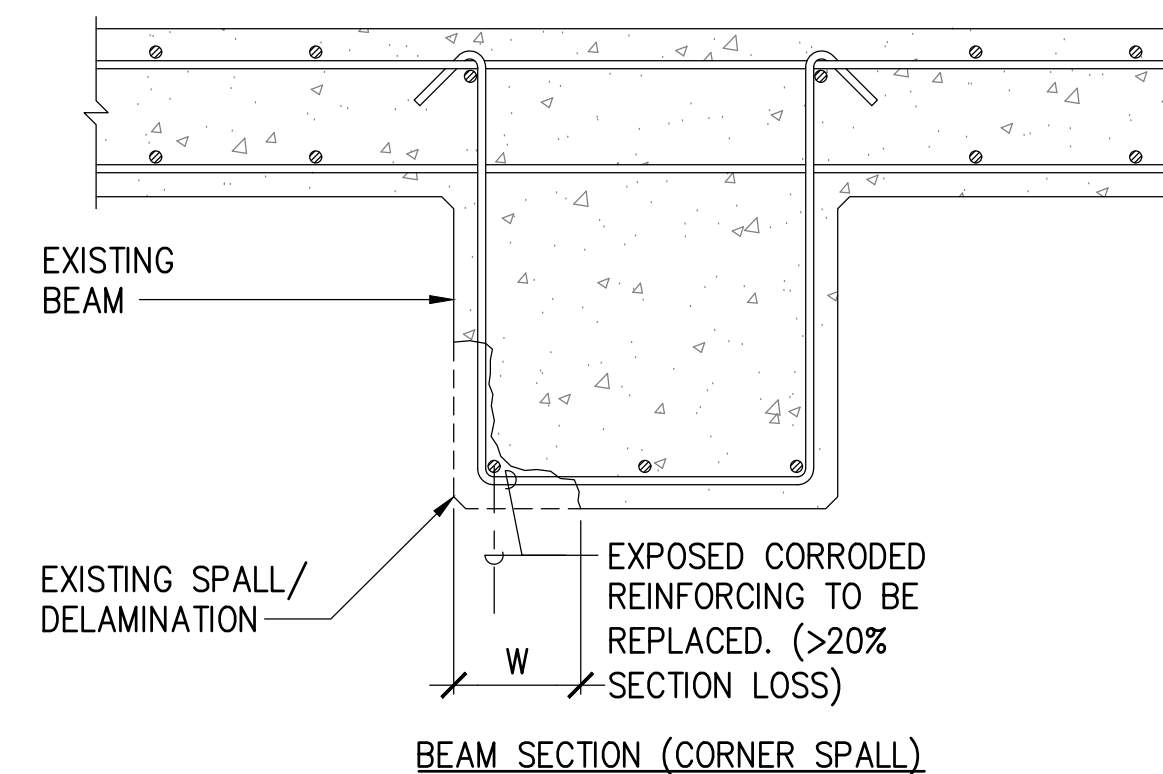
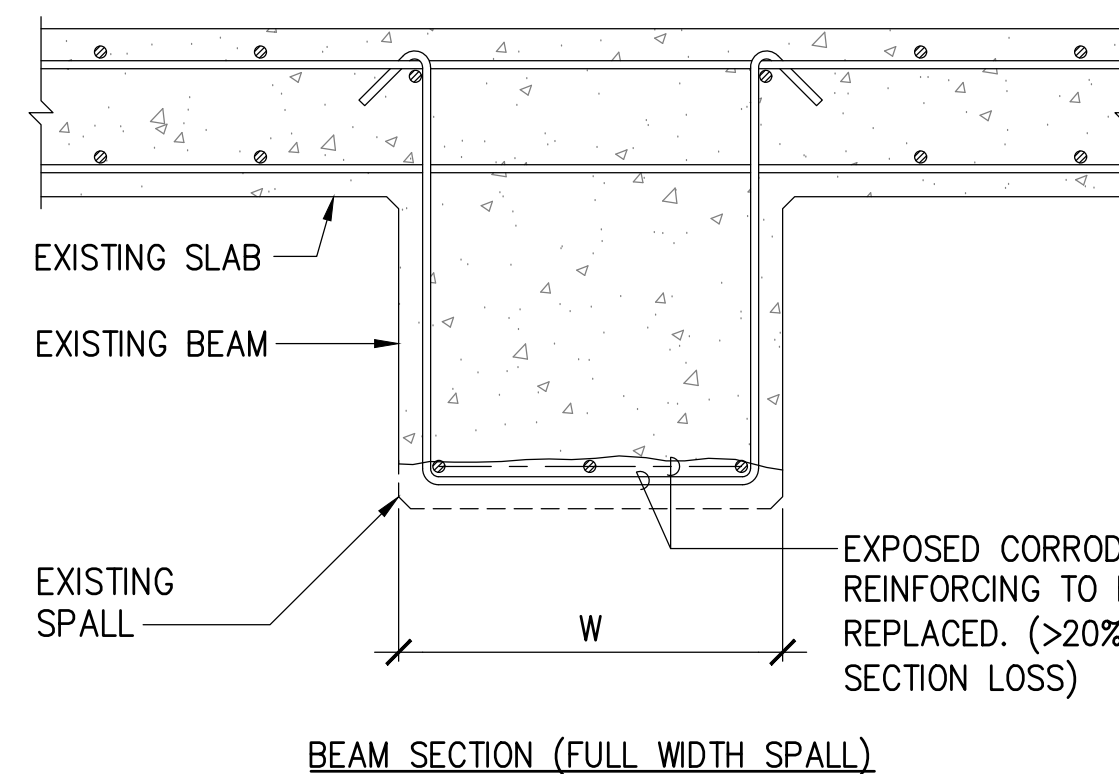
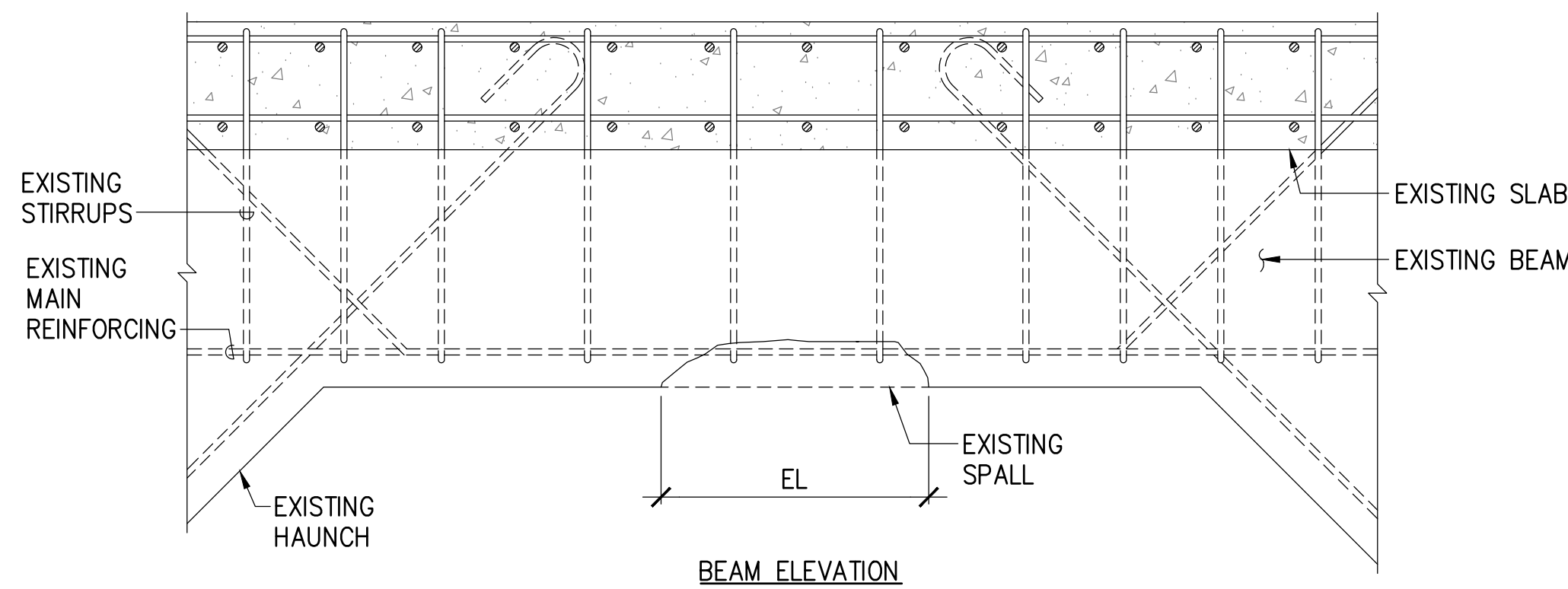

PAY AREA:
 HL = HEIGHT OF REPAIR (LEFT SIDE)
 HR = HEIGHT OF REPAIR (RIGHT SIDE)
 W = ORIGINAL WIDTH OF BEAM/GIRDER SPALL
 EL = EXISTING LENGTH OF SPALL
 NL = LENGTH OF REPAIR

PAY AREA = (HL+HR+W)NL

NOTES:

- PAY AREA SHALL BE THE TOTAL REPAIRED AREA ON ALL BEAM FACES. IF HL, HR OR W VARY ALONG THE LENGTH OF REPAIR, PAY AREA SHALL BE CALCULATED INDIVIDUALLY FOR EACH BEAM FACE.

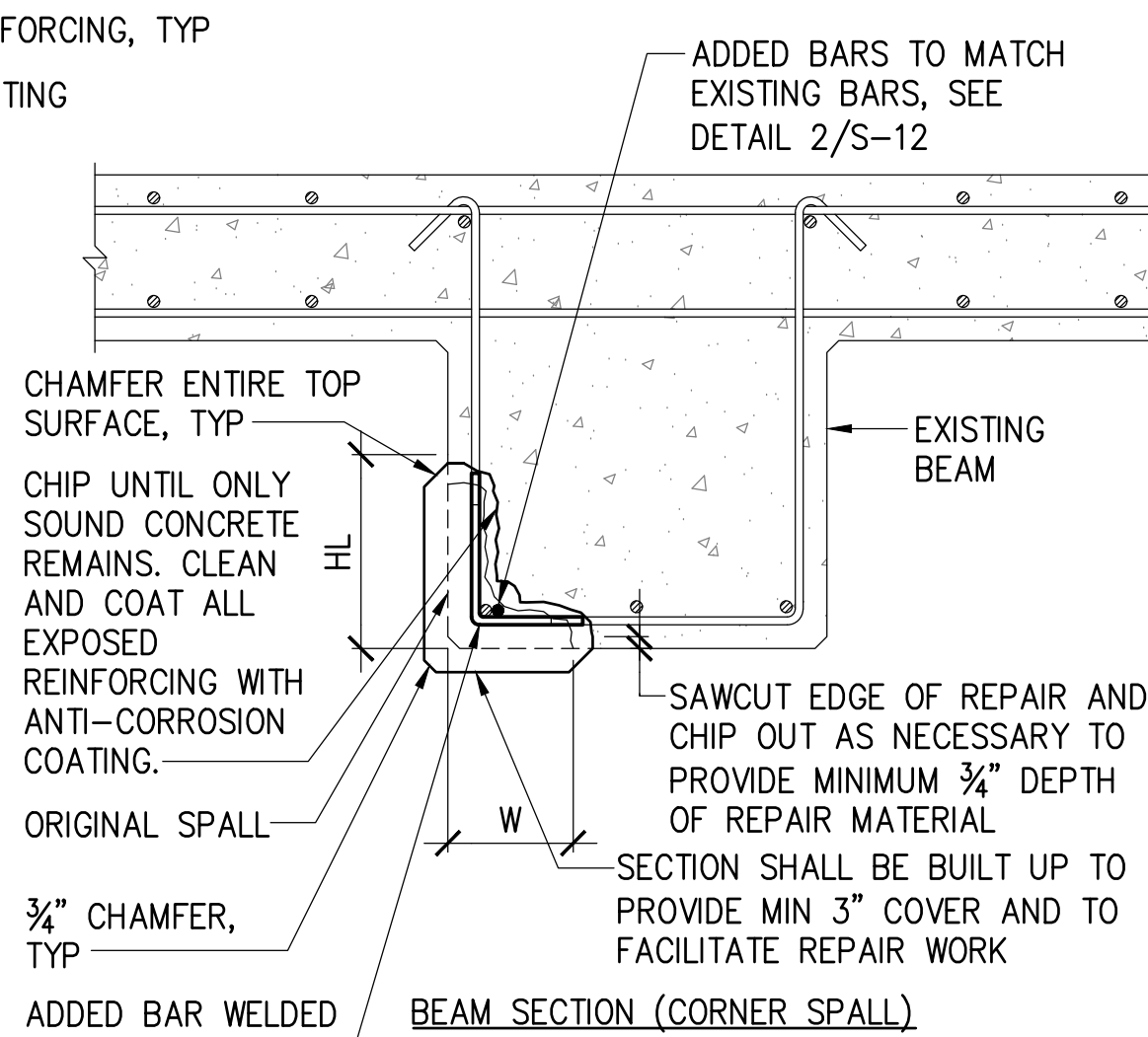
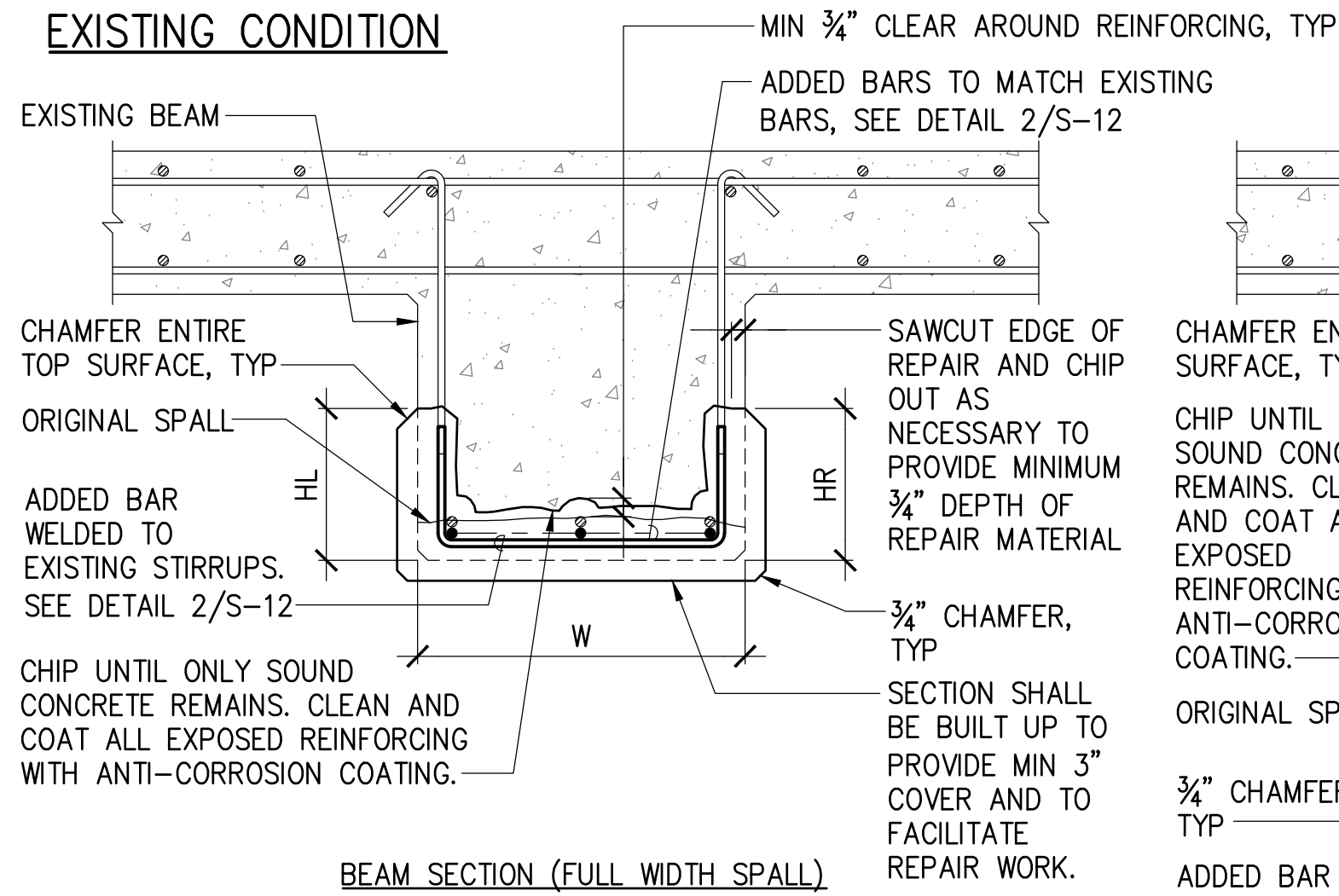
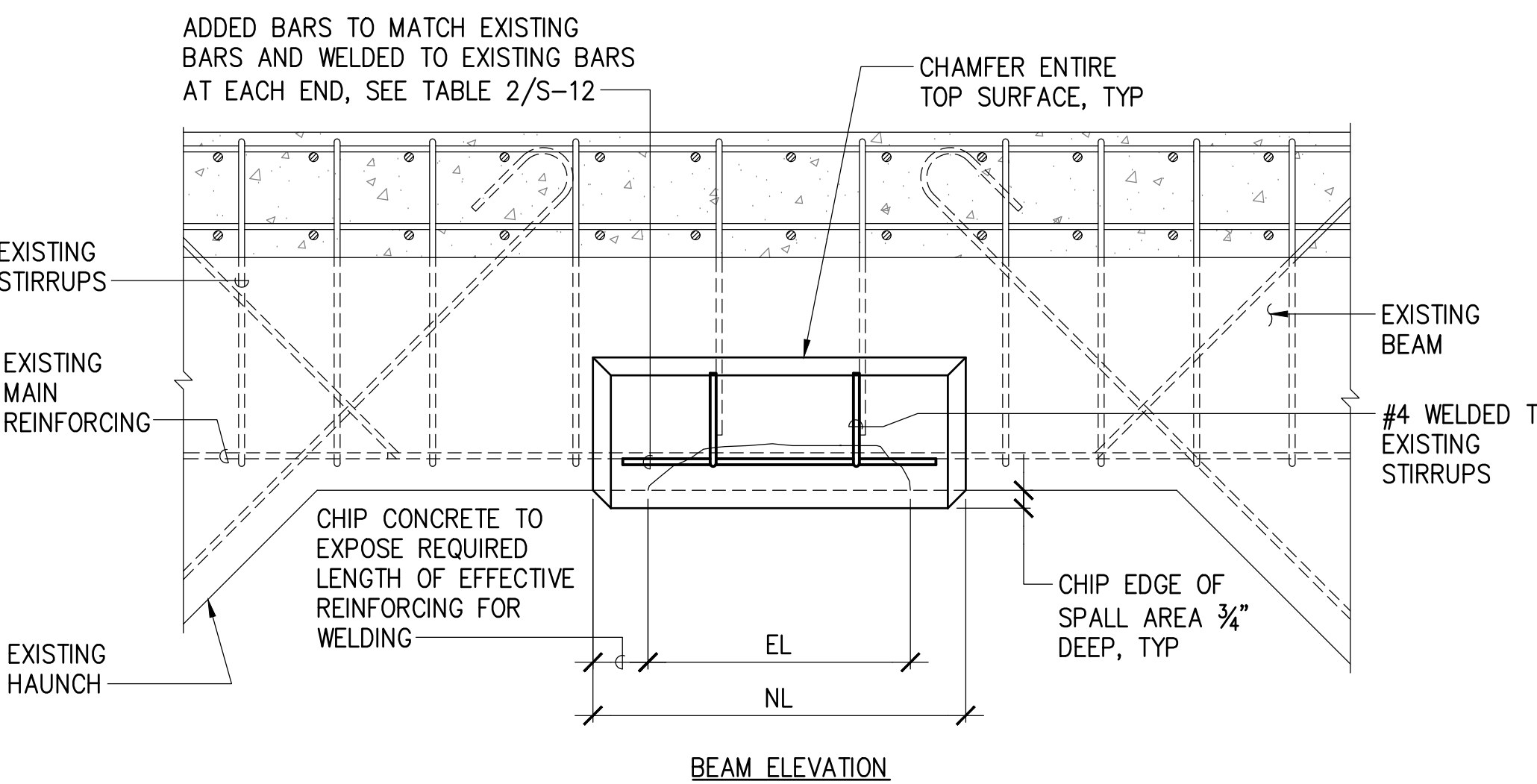

EXISTING CONDITION

REPAIRED CONDITION

2 BEAM SPALL REPAIR WITH REINFORCING STEEL REPLACEMENT (TYPE BR)
 S-9 NOT TO SCALE

REVISION	DATE	DESCRIPTION	BY	APPROVED
STATE OF HAWAII DEPARTMENT OF TRANSPORTATION HARBORS DIVISION				
JOB TITLE SUBSTRUCTURE REPAIRS AT PIERS 16 AND 17 HONOLULU HARBOR, OAHU, HAWAII				
SHEET TITLE BEAM SPALL REPAIR DETAILS				
DESIGNED BY: GO	JOB NUMBER			SHEET
DRAWN BY: DL	S10852			S-9
CHECKED BY: GM	DATE: 04/2023			11 of 14 SHTS.
SCALE: AS SHOWN				

GRANT J. OKUNICA
 LICENSED PROFESSIONAL ENGINEER
 No. 13001-S
 HAWAII, U.S.A.

THIS WORK WAS PREPARED BY ME OR UNDER MY SUPERVISION
 EXP. 4-30-24
 MKE ASSOCIATES LLC

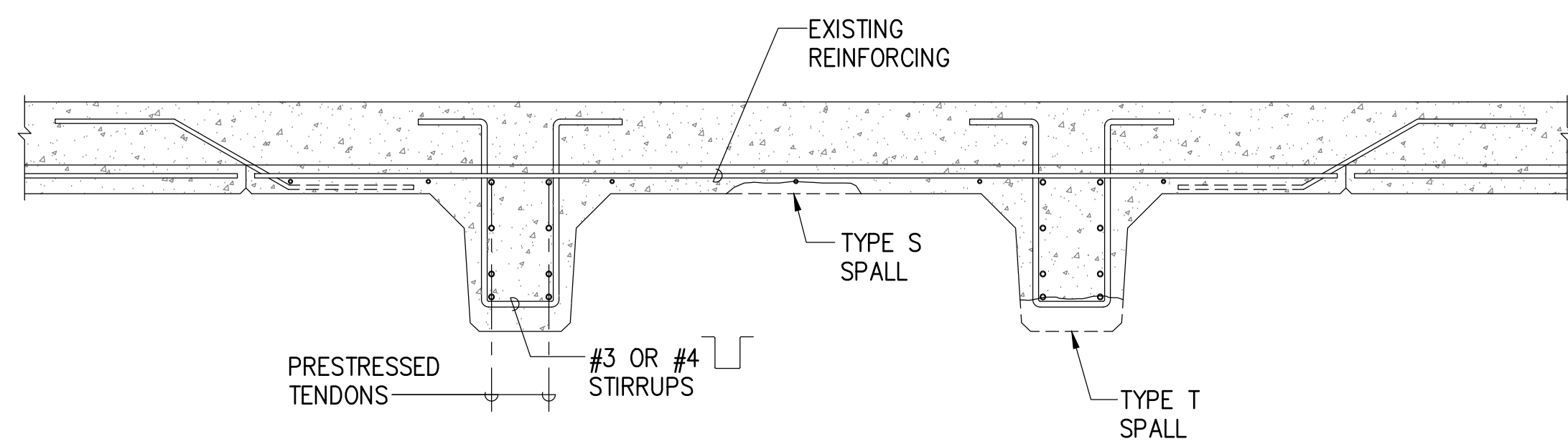

TYPICAL SECTION

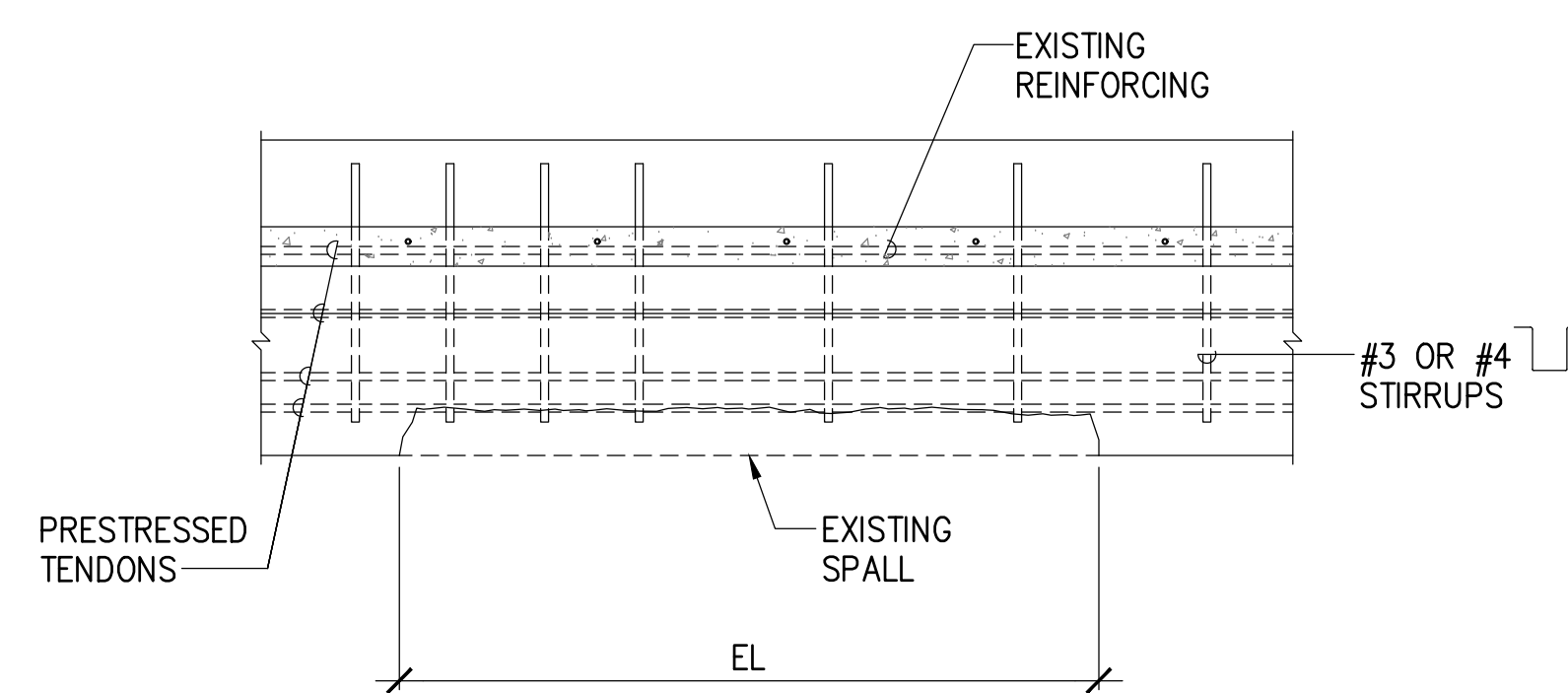

TYPE T SPALL SIDE ELEVATION

EXISTING CONDITION

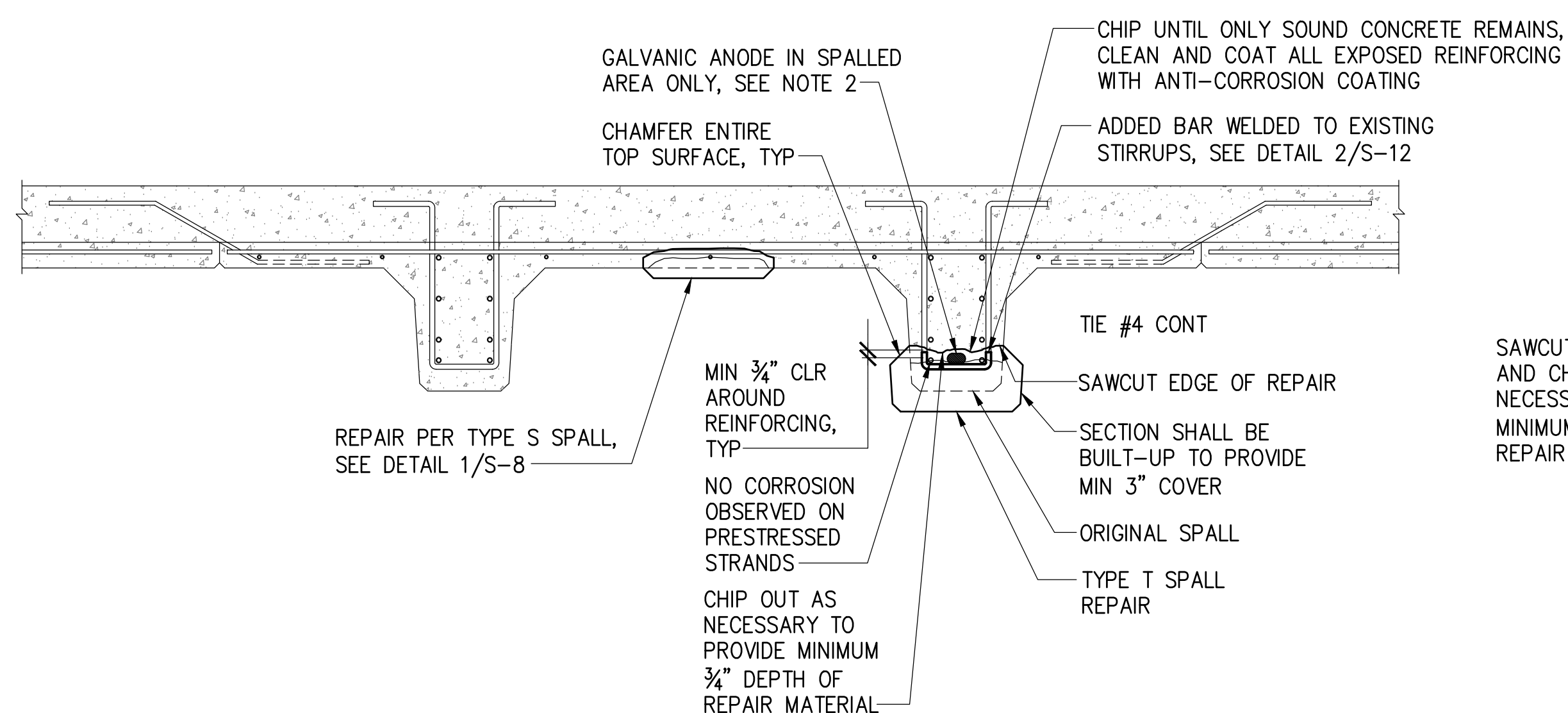

TYPICAL SECTION

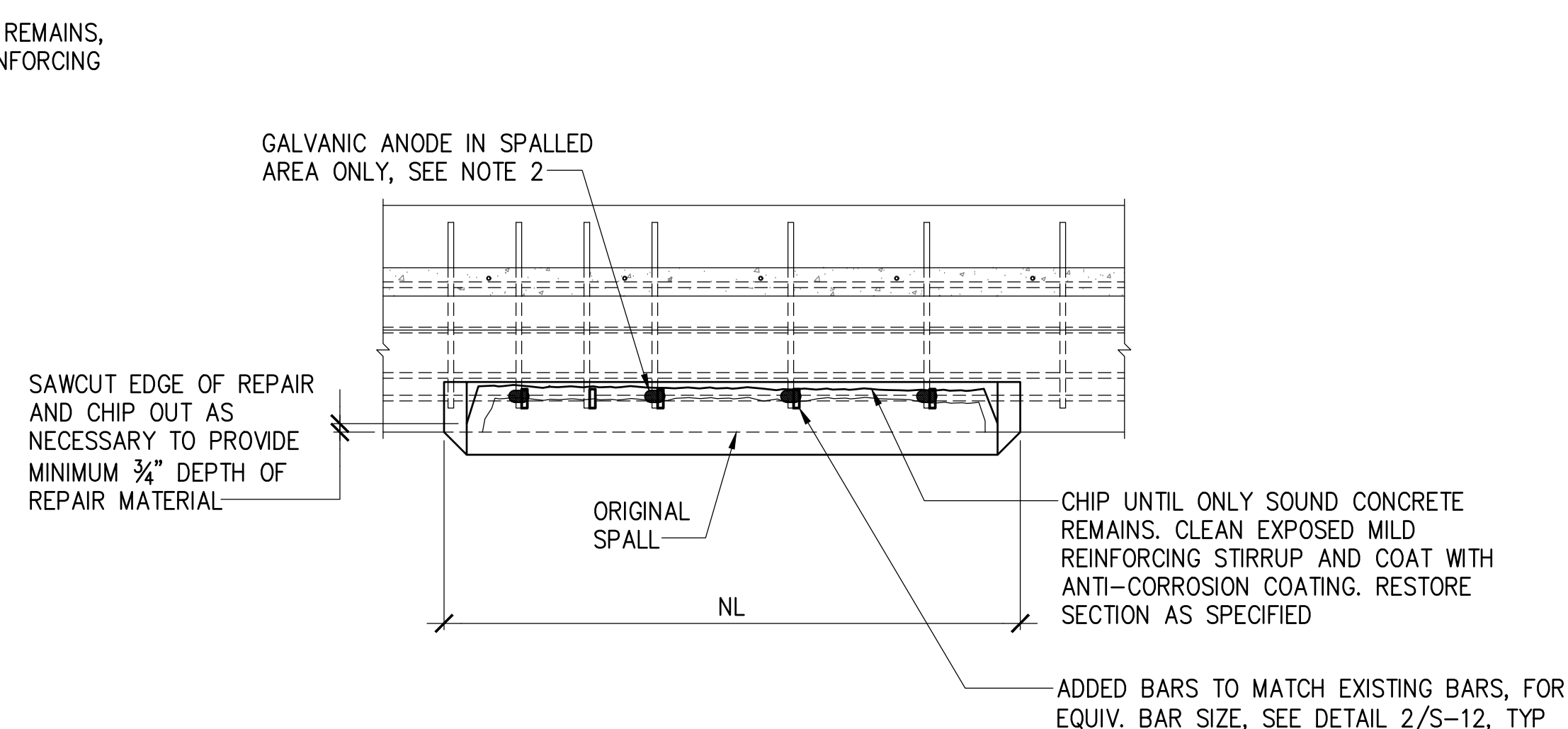

TYPE T SPALL SIDE ELEVATION

REPAIRED CONDITION

CALCULATION OF PAY LENGTH:

EL = EXISTING LENGTH OF SPALL
 NL = PAY LENGTH FOR TYPE T SPALL

NOTES:

1. CONCRETE TOPPING REINFORCING STEEL NOT SHOWN FOR CLARITY.
2. GALVANIC ANODES SHALL BE INSTALLED AT 17" MAX ALONG LENGTH OF REPAIR.
3. ANY PRESTRESSED STRAND WHICH HAS LOST MORE THAN 20 PERCENT OF ITS CROSS-SECTIONAL AREA SHALL BE CALLED TO THE ATTENTION OF THE HARBORS DIVISION CONSTRUCTION ENGINEER.
4. TYPE S SPALLS ON DOUBLE TEES SHALL BE REPAIRED AND PAID FOR SIMILAR TO TYPICAL TYPE S SPALLS, SEE DETAIL 1/S-8.

	THIS WORK WAS PREPARED BY ME OR UNDER MY SUPERVISION EXP. 4-30-24 <i>Grant J. Okuniga</i> MKE ASSOCIATES LLC		REVISION DATE DESCRIPTION BY APPROVED	
	STATE OF HAWAII DEPARTMENT OF TRANSPORTATION HARBORS DIVISION			
	JOB TITLE SUBSTRUCTURE REPAIRS AT PIERS 16 AND 17 HONOLULU HARBOR, OAHU, HAWAII			
	SHEET TITLE PRESTRESS DOUBLE TEE SPALL REPAIR DETAILS			
DESIGNED BY: GO DRAWN BY: DL CHECKED BY: GM DATE: 04/2023 SCALE: AS SHOWN	JOB NUMBER S10852		SHEET S-10 12 OF 14 SHTS.	

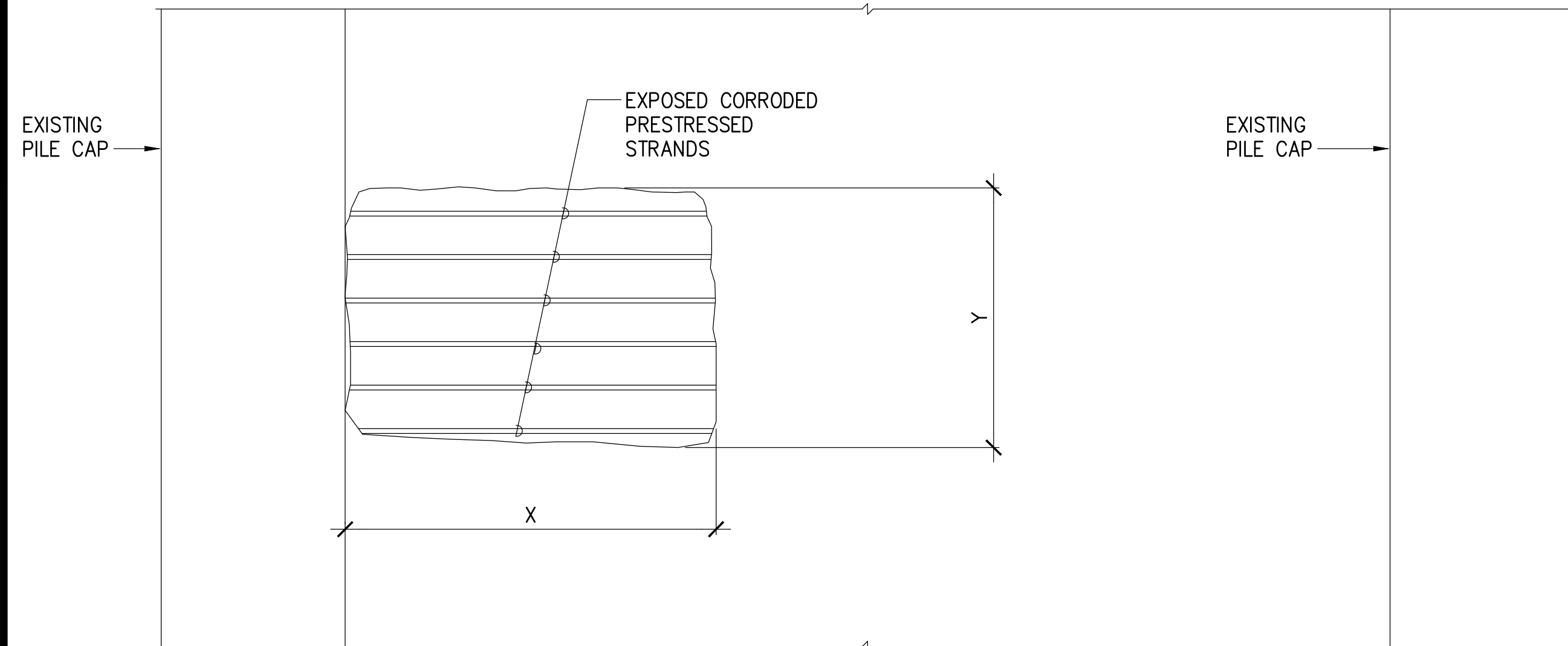

SOFFIT PLAN

EXISTING SPALL AREA = X x Y

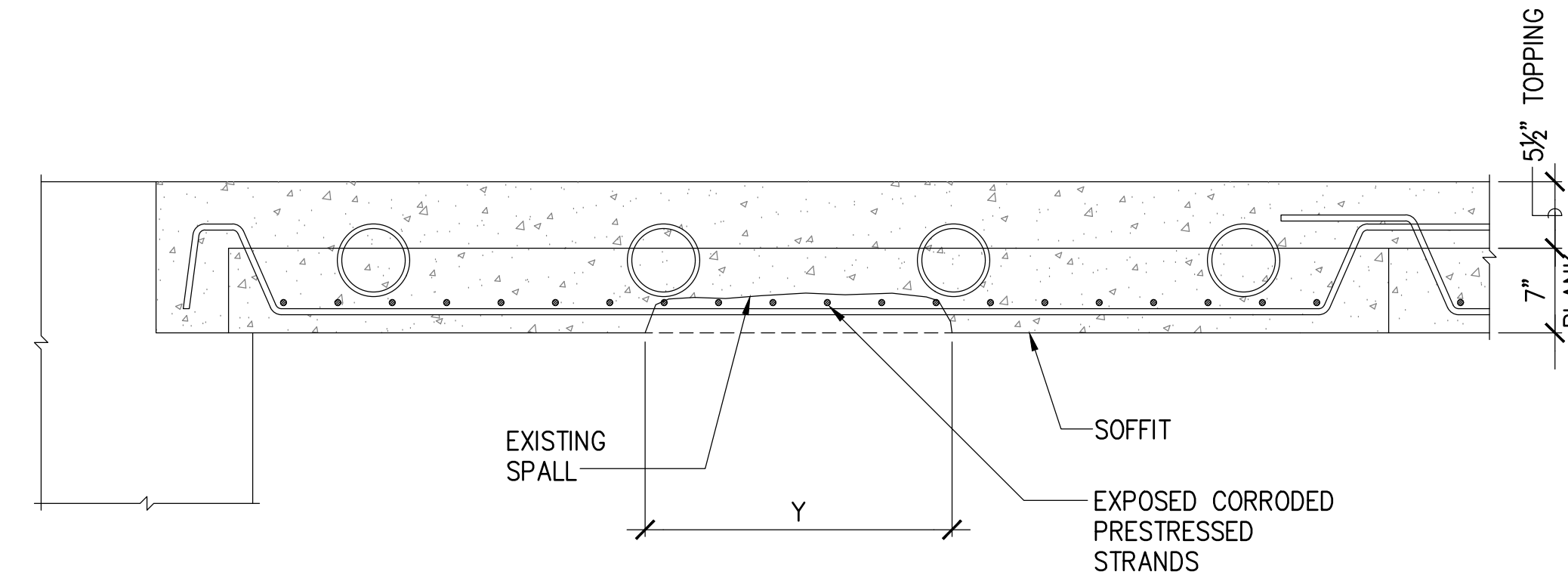

SECTION

EXISTING CONDITION

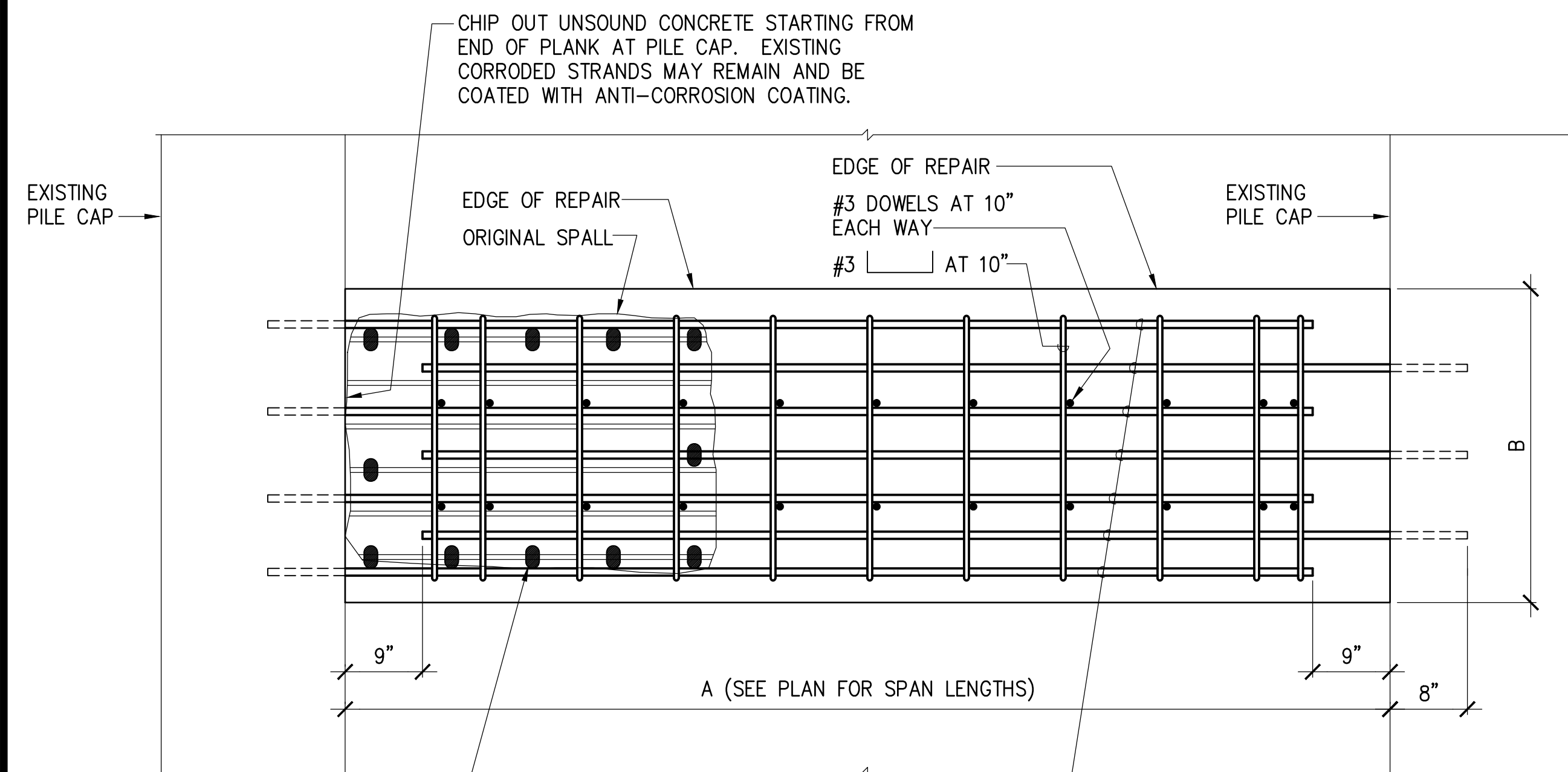

SOFFIT PLAN

PAY AREA = A x B

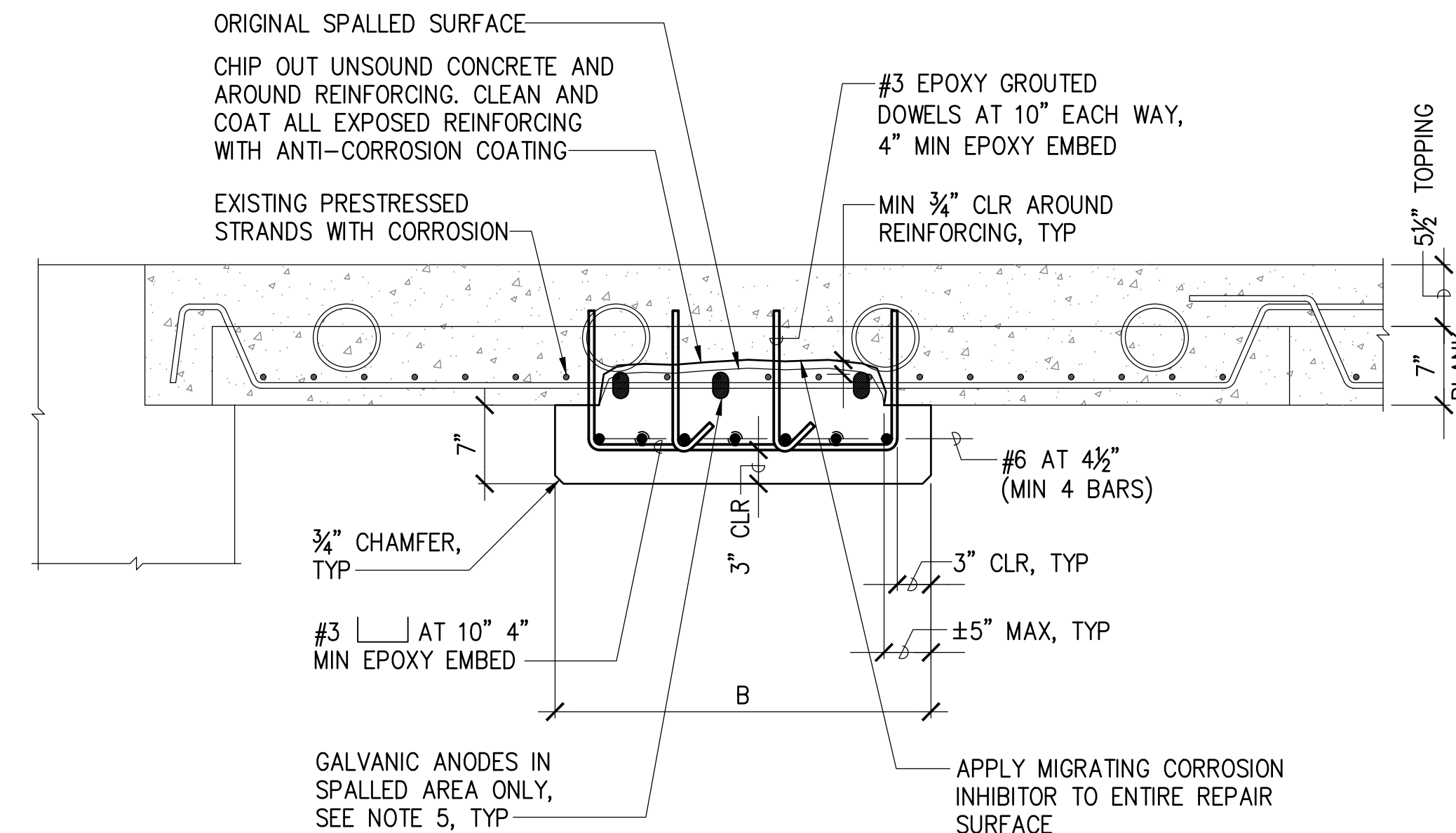

TYPICAL REPAIR SECTION

REPAIRED CONDITION

NOTES:

- REPAIR WIDTH (B) SHALL BE WIDER THAN ORIGINAL SPALL WIDTH (Y).
- REPAIR LENGTH (A) SHALL EXTEND OVER ENTIRE CLEAR DISTANCE BETWEEN BEAMS.
- AVOID DAMAGING EXISTING STRANDS WHEN DRILLING HOLES FOR DOWELS.
- DOWELS ARE NOT REQUIRED AT LOCATIONS WHERE INSTALLATION IS NOT POSSIBLE DUE TO FULL DEPTH REPAIR OF THE EXISTING SLAB.
- GALVANIC ANODES SHALL BE INSTALLED AT 17" MAX AROUND THE PERIMETER OF THE SPALLED AREA. FOR SPALLS LESS THAN 1 SQUARE FOOT IN SIZE, INSTALL ONE GALVANIC ANODE IN SPALLED AREA.
- SHALLOW PRECAST PLANK SOFFIT SPALLS WITH NO EXPOSED PRESTRESSING STRANDS MAY BE REPAIRED PER DETAIL 1/S-12.

		REVISION DATE DESCRIPTION BY APPROVED	
STATE OF HAWAII DEPARTMENT OF TRANSPORTATION HARBORS DIVISION			
JOB TITLE SUBSTRUCTURE REPAIRS AT PIERS 16 AND 17 HONOLULU HARBOR, OAHU, HAWAII			
SHEET TITLE PRECAST PLANK SOFFIT SPALL REPAIR DETAILS			
DESIGNED BY: GO	JOB NUMBER		SHEET
DRAWN BY: DL	S10852		S-11
CHECKED BY: GM			
DATE: 04/2023			
SCALE: AS SHOWN	13 of 14 SHTS.		

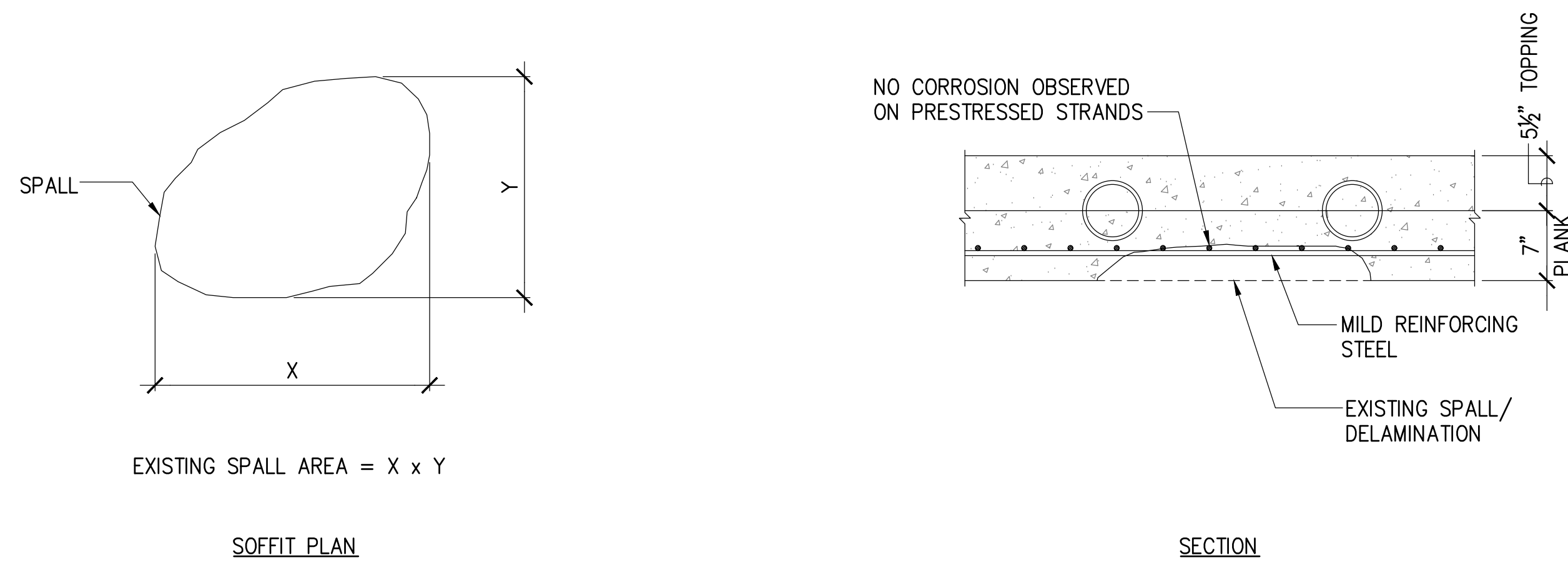

EXISTING CONDITION

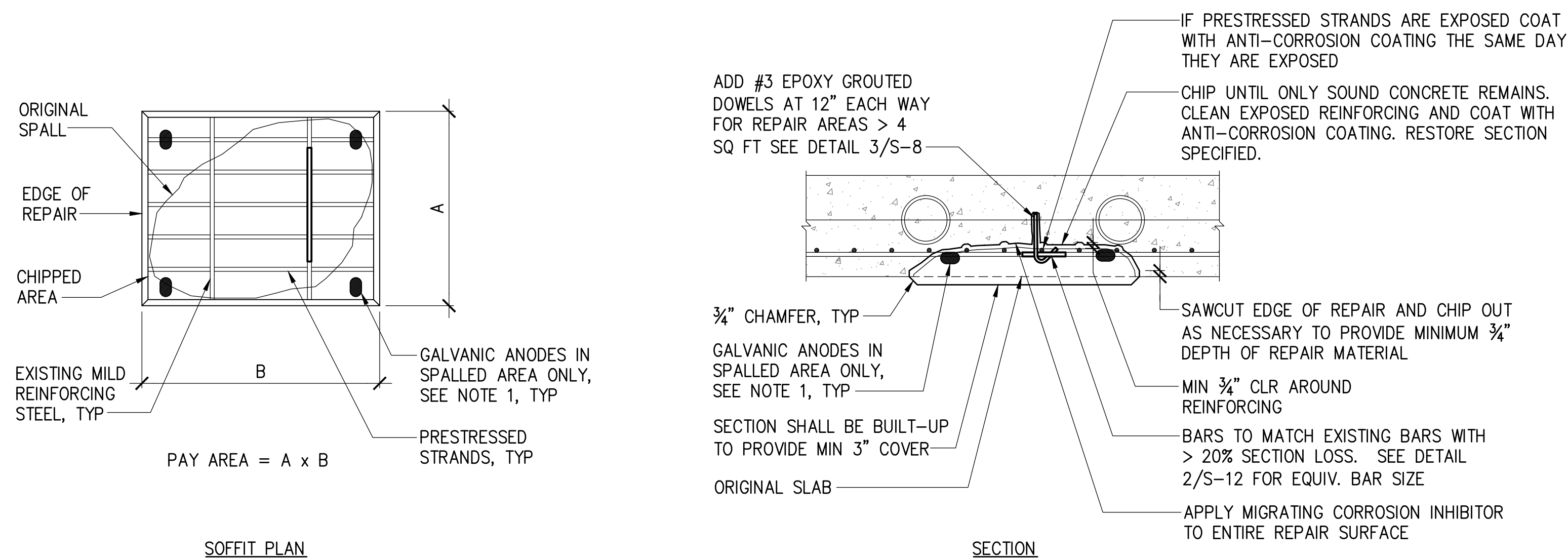

REPAIRED CONDITION

NOTES:

1. GALVANIC ANODES SHALL BE INSTALLED AT 17" AROUND THE PERIMETER OF THE REPAIRS. FOR SPALLS LESS THAN 1 SQUARE FOOT IN SIZE, INSTALL ONE GALVANIC ANODE IN SPALLED AREA.
2. ALTERNATE REPAIR SHALL BE ONLY FOR SHALLOW PRECAST PLANK SOFFIT SPALLS WITH NO CORROSION OF PRESTRESSING STRANDS.

1 ALTERNATE PRECAST PLANK SOFFIT SPALL REPAIR (TYPE P)
S-12 NOT TO SCALE

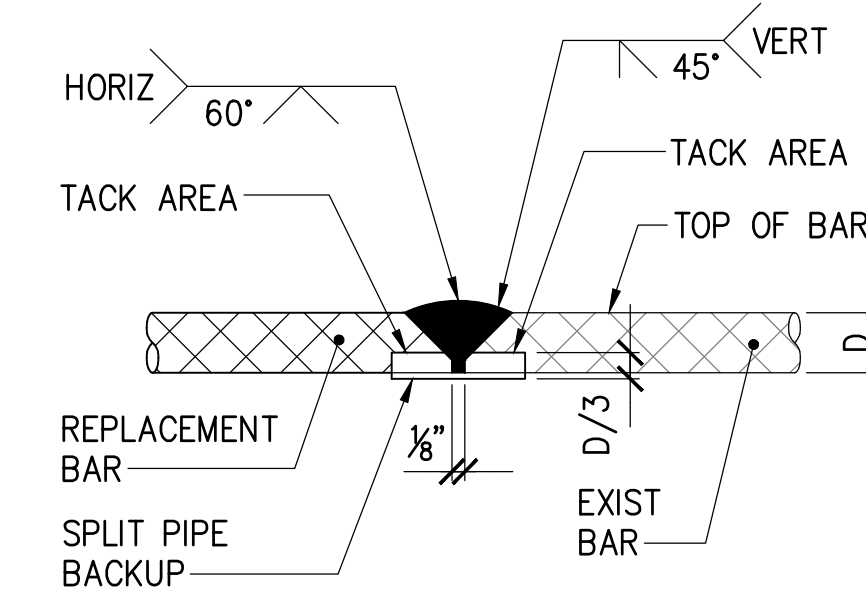

A BUTT SPlice

USE DETAIL A FOR #7 BARS AND LARGER

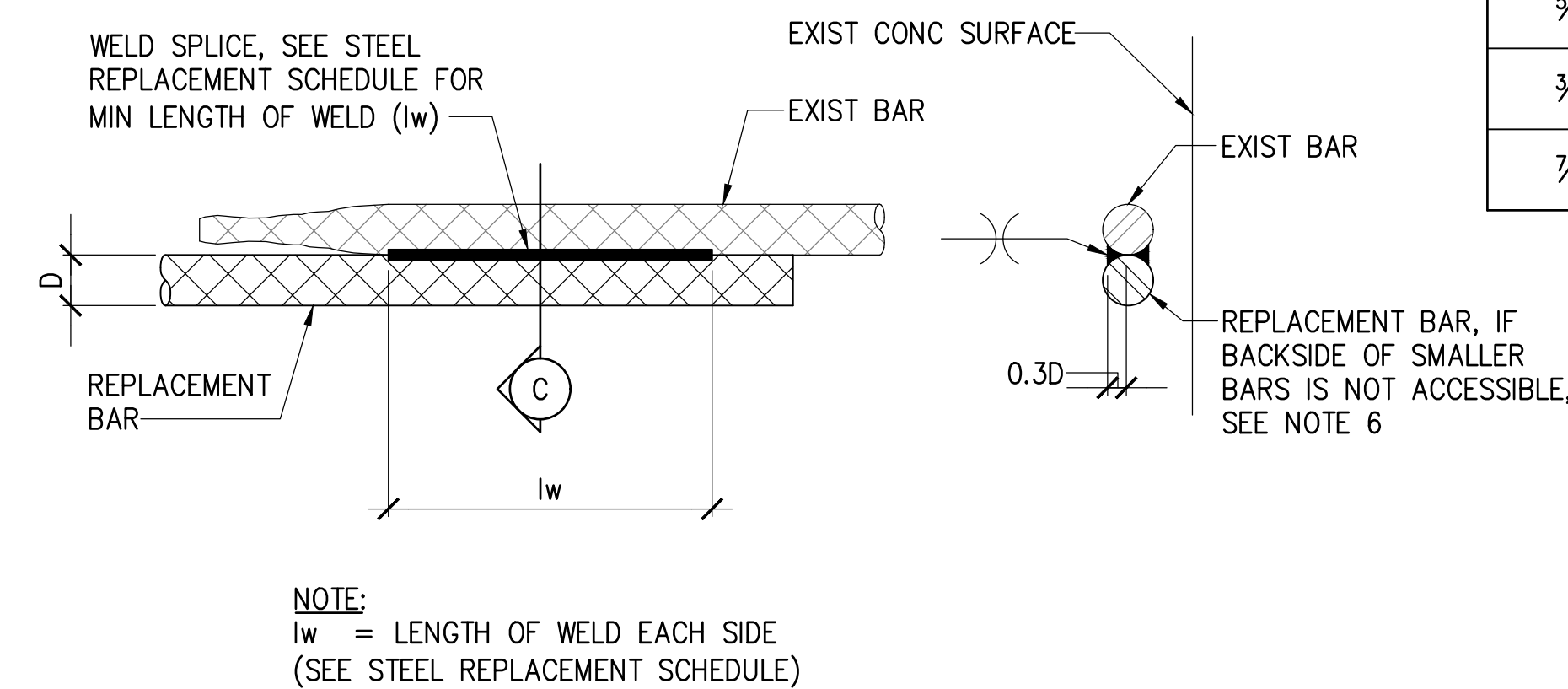

B LAP SPlice

C SECTION

USE DETAIL B FOR #6 BARS AND SMALLER

REINFORCING STEEL WELDING NOTES:

1. CHIP, GRIND, OR GOUGE TO SOUND METAL BEFORE WELDING.
2. CLEAN EXIST REBAR AND PREPARE ACCORDING TO SPECIFICATIONS. APPLY COATING AFTER WELDING.
3. SEE STEEL REPLACEMENT SCHEDULE BELOW FOR REPLACEMENT BAR SIZE.
4. USE E70 ELECTRODES.
5. SEE AWS D1.4 FOR WELDING PROCESS AND OTHER DETAILS.
6. FOR WELDING OF #3, #4, AND #5 REPLACEMENT REINFORCING, WELDING MAY BE PERFORMED ON ONE SIDE ONLY, IF lw IS INCREASED TO lw1 AS FOLLOWS

STEEL REPLACEMENT SCHEDULE				
SIZE OF EXISTING REINFORCING		SIZE OF REPLACEMENT REINFORCING	MINIMUM LENGTH OF WELD EACH SIDE (lw)	MINIMUM LENGTH OF WELD ONE SIDE lw1
SQUARE	ROUND			
3/8"	#3, #4	#4	2"	4"
1/2"	#5	#5	2 1/2"	5"
5/8"	#6	#6	3 1/2"	-
3/4"	#7	#7	-	-
7/8"	#8	#8	-	-

2 REINFORCING STEEL SPlice DETAIL
S-12 NOT TO SCALE

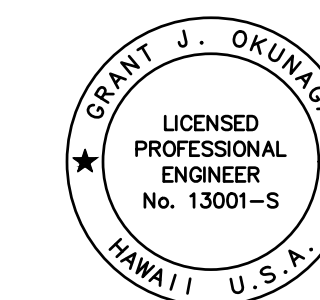

THIS WORK WAS PREPARED BY ME OR UNDER MY SUPERVISION
EXP. 4-30-24
MKE ASSOCIATES LLC

REVISION	DATE	DESCRIPTION	BY	APPROVED
STATE OF HAWAII DEPARTMENT OF TRANSPORTATION HARBORS DIVISION				
JOB TITLE SUBSTRUCTURE REPAIRS AT PIERS 16 AND 17 HONOLULU HARBOR, OAHU, HAWAII				
SHEET TITLE TYPICAL REPAIR DETAILS				
DESIGNED BY: GO				SHEET S-12
DRAWN BY: DL				JOB NUMBER S10852
CHECKED BY: GM				
DATE: 04/2023				
SCALE: AS SHOWN				14 OF 14 SHTS.